

BOARD OF WATER SUPPLY, COUNTY OF KAUAI

On March 16, 2020, Governor David Y. Ige issued a Supplementary Emergency Proclamation related to COVID-19 which suspended Chapter 92 of the Hawai'i Revised Statutes ("HRS"), relating to Public Agency Meetings and Records (commonly referred to as the Sunshine Law) to the extent necessary in order to enable boards to conduct business in-person or through remote technology without holding meetings open to the public. Boards shall consider reasonable measures to allow public participation consistent with social distancing practices, such as providing notice of meetings, allowing the submission of written testimony on items which have been posted on an agenda, live streaming of meetings, and posting minutes of meetings online. No board deliberation or action shall be invalid, if such measures are not taken.

In accordance with the Governor's Proclamations including the stay-at-home order and the Mayor's Proclamations and Emergency Rules, the Board of Water Supply meetings will be conducted as follows until further notice:

- Board meetings will be held via remote technology to be consistent with social distancing practices and stay-at-home orders.
- Board members and/or resource individuals may appear via remote technology.
- Board meetings will continue to be noticed pursuant to HRS Chapter 92.
- Written testimony on any agenda item will continue to be accepted.
 - Written testimony may be submitted to Edie Ignacio-Neumiller, the Commission Support Clerk via email at eineumiller@kauaiwater.org by the close of business the day before the Board meeting is scheduled or mailed to the Board of Water Supply at 4398 Pua Loke Street, Lihu'e, Kaua'i, Hawai'i 96766 with attention to the Commission Support Clerk. The public is asked to please provide sufficient time if mailing in public testimony.
 - Oral testimony may be submitted by leaving a voice message at (808) 245-5412.
 - The Commission Support Clerk will provide electronic copies of public testimony received, if any, to the Board members prior to the start of the meeting.
- Board meeting minutes will continue to comply with HRS Chapter 92 and be posted to the Board's website at http://www.kauaiwater.org/cp_waterboard_agendas.asp.

For more information on COVID-19 and to access the Governor's Proclamations please visit: <https://hawaiicovid19.com/>.

For County of Kaua'i information, including the Mayor Kawakami's daily updates, Proclamations, and Emergency Rules, please visit: <http://www.kauai.gov/COVID-19>.

BOARD OF WATER SUPPLY of the COUNTY OF KAUA'I

REGULAR MEETING

Board Room, Second Floor, Department of Water
4398 Pua Loke Street, Līhu'e, Kaua'i, Hawai'i 96766

Thursday, October 22, 2020
10:00 a.m. or soon thereafter

PUBLIC ACCESS: +1-415-655-0001 United States Toll
Access code: 126 004 1568# Password: 4398#

To listen live to the Regular Board meeting, members of the public may use the public access number and enter the access code. No live public testimony will be received. If members of the public require technical assistance with please contact: informationtechnology@kauaiwater.org

A. CALL TO ORDER

B. ROLL CALL

C. ACCEPTANCE OF AGENDA

D. MEETING MINUTES

Review and Approval of:

Regular Board Meeting – September 24, 2020

Special Board Meeting – September 18, 2020

Special Board Meeting – September 24, 2020

Review and Approval of Executive Session:

Regular Board Meeting – September 24, 2020

Special Board Meeting – September 18, 2020

Special Board Meeting – September 24, 2020

E. CORRESPONDENCE/ANNOUNCEMENTS/PUBLIC TESTIMONY

1. Correspondence from Ms. Katrina Medina, CBRE, Inc. Manager regarding Plumbing Code Amendment Requirement Installation of Back Flow Preventors, dated September 21, 2020
2. Correspondence from Mr. George Barker to Chair Kurt Akamine and Board Member Gregory Kamm regarding Water Bill, received September 21, 2020
3. Correspondence from Mr. George Barker to Vice Chair Julie Simonton regarding Water Bill, received September 30, 2020

F. BOARD COMMITTEE & PERMITTED INTERACTION GROUP REPORTS

G. OLD BUSINESS

1. *Manager's Report No. 19-47* - Discussion and Possible Action for Board Approval to enter into the First Amendment to the Memorandum of Agreement between the Department of Public Works, County of Kaua'i and the Board of Water Supply, County of Kaua'i for the County's Kahilihoho Road Culvert Repair Project and expenditure of funds in the amount of \$44,100.00 (*Update*)

G. OLD BUSINESS (cont'd)

2. Manager's Report No. 20-24 – Discussion and Possible Action for the Proposed Amendment to the Memorandum of Agreement (Drainage) between Godwin M. Esaki and Janet M. Esaki, individually and as trustees of the Godwin M. Esaki Revocable Living Trust, and the Janet M. Esaki Revocable Living Trust, TMK: (4) 4-6-011:125, Kapa'a, Kaua'i, Hawai'i and the Board of Water Supply, dated August 21, 2017
3. Manager's Report No. 20-41 - Waiahi Surface Water Treatment Plant Renovation Construction Cost Progress Report (*Update*)

H. NEW BUSINESS

1. Manager's Report No. 21-12 – Discussion and Possible Action on the Fourth Amendment to Contract No. 639 Job No. 17-10, WP2020 Project No. KW-07 Rehabilitate Paua Valley Tank #1, 0.5MG Concrete, with KAI Hawaii Inc. for a time extension of 150 days and for additional design funding in the amount of \$212,719.00

I. STAFF REPORTS MONTHLY

1. Discussion and Receipt of the Kaua'i County Water Department's Statement of Revenues and Expenditures
 - a. September Monthly Summary Budget
 - b. Accounts Receivable Aging Summary
2. Discussion and Receipt of the Report by the Information & Education Specialist on Public Relations Activities
3. Discussion and Receipt of the Chief of Operation's Summary Report on Operational Activities
4. Discussion and Receipt of the Manager and Chief Engineer's Monthly Update Regarding Activities of Note of the DOW
 - a. Build America Bond - Quarterly Report (*July - September 2020*)

QUARTERLY (*July - September 2020*)

1. Discussion and Receipt of the DOW's Quarterly Project Status Update
 - a. Construction Management Division Status
 - b. Engineering Division Design Status
 - c. Water Resources & Planning Division Status
 - d. Information Technology Strategic Plan Status

J. EXECUTIVE SESSION

Pursuant to Hawai'i Revised Statutes(HRS) §92-7(a), the Board may, when deemed necessary, hold an executive session on any agenda item without written public notice if the Executive Session was not anticipated in advance. Any such executive session shall be held pursuant to HRS §92-4 and shall be limited to those items described in HRS §92-5(a).

J. EXECUTIVE SESSION (cont'd)

1. Pursuant to Hawai'i Revised Statutes § 92-4 and § 92-5(a)(2) and (4), the purpose of this Executive Session is for the Board to consider the hiring of an interim manager and chief engineer where consideration of matters affecting privacy will be involved; provided that if the individual concerned requests an open meeting, an open meeting shall be held; and for the Board to consult with the Board's attorney on questions and issues pertaining to the Board's powers, duties, privileges, immunities, and liabilities.
2. Pursuant to Hawai'i Revised Statutes § 92-4 and § 92-5(a)(2) and (4), the purpose of this Executive Session is for the Board to consider the hiring of a manager and chief engineer where consideration of matters affecting privacy will be involved; provided that if the individual concerned requests an open meeting, an open meeting shall be held; and for the Board to consult with the Board's attorney on questions and issues pertaining to the Board's powers, duties, privileges, immunities, and liabilities as it relates to the Report of the Permitted Interaction Group of the Kaua'i County Board of Water Supply.
3. Pursuant to Hawai'i Revised Statutes § 92-4 and § 92-5(a)(4), the purpose of this Executive Session is for the Board to consult with the Board's attorney on questions and issues pertaining to the Board's powers, duties, privileges, immunities, and liabilities as it relates to Manager's Report No. 20-24 – Discussion and Possible Action for the Proposed Amendment to the Memorandum of Agreement (Drainage) between Godwin M. Esaki and Janet M. Esaki, individually and as trustees of the Godwin M. Esaki Revocable Living Trust, and the Janet M. Esaki Revocable Living Trust, TMK: (4) 4-6-011:125, Kapa'a, Kaua'i, Hawai'i and the Board of Water Supply, dated August 21, 2017.
4. Pursuant to Hawai'i Revised Statutes § 92-4 and § 92-5(a)(2), the purpose of this Executive Session is for the Board to consider the discipline of an officer or employee or of charges brought against the officer or employee, where consideration of matters affecting privacy will be involved; provided that if the individual concerned requests an open meeting, an open meeting shall be held.
5. Pursuant to Hawai'i Revised Statutes § 92-4 and § 92-5(a)(2), the purpose of this Executive Session is for the Board to consider the discipline of an officer or employee or of charges brought against the officer or employee, where consideration of matters affecting privacy will be involved; provided that if the individual concerned requests an open meeting, an open meeting shall be held.
6. Pursuant to Hawai'i Revised Statutes § 92-4 and § 92-5(a)(4), the purpose of this Executive Session is for the Board to consult with the Board's attorney on questions and issues pertaining to the Board's powers, duties, privileges, immunities, and liabilities as those relate to *Shelly Seefeldt; DARREN Zastawny vs. The Parrish Collection, LLC., et al., CIV-19-1-0016; The Parrish Collection, LLC., Third Party Plaintiff, vs. County of Kaua'i Department of Water, Third Party Defendant.*

K. TOPICS FOR NEXT BOARD OF WATER SUPPLY MEETING (November 2020)

1. Discussion and Receipt of the Department of Water's Draft Audit Financial Statements and Independent Auditor's Report by Accuity, Inc. for Fiscal Year 2020 and 2019
2. Election of Officers for 2021
3. Board Meeting Dates for 2021

- L. TOPICS FOR FUTURE BOARD OF WATER SUPPLY MEETINGS
 - 1. Department of Water Performance Audit (Update)
 - 2. Table of Organization Workshop
 - 3. Discussion and Possible Action to establish Fiscal Policies and Procedures
 - 4. Baseyard Master Plan Workshop

- N. UPCOMING EVENTS

- O. NEXT WATER BOARD MEETING
 - 1. Thursday, November 19, 2020, 10:00 a.m.
 - 2. Thursday, December 17, 2020, 10:00 a.m.
 - 3. Thursday, January 21, 2021, 10:00 a.m.
 - 4. Thursday, February 25, 2021, 10:00 a.m.

- P. ADJOURNMENT

PUBLIC TESTIMONY

The Board is required to afford all interested persons an opportunity to present testimony on any agenda item. At each Board meeting, the Board will accept oral and written testimony on any agenda item at item E Correspondence/Announcements/Public Testimony.

If any member of the public wishes to submit written testimony, please submit the written testimony to Edie Ignacio-Neumiller, the Commission Support Clerk via email at least two (2) business days prior to the meeting and the Commission Support Clerk will provide copies to the Board members or bring eight (8) copies with you the day of the meeting.

SPECIAL ASSISTANCE

If you need an auxiliary aid/service, other accommodation due to a disability, or an interpreter for non-English speaking persons, please contact Edie Ignacio-Neumiller at (808) 245-5406 or eineumiller@kauaiwater.org as soon as possible. Requests made as early as possible will allow adequate time to fulfill your request. Upon request, this notice is available in alternate formats such as large print, braille, or electronic copy.

Draft Minutes

MINUTES
BOARD OF WATER SUPPLY
September 24, 2020

The Board of Water Supply, County of Kaua'i, met in regular meeting **via remote** in Līhu'e on Thursday, September 24, 2020. Chair Kurt Akamine called the meeting to order at 10:02 a.m. The following Board members were present:

BOARD: Mr. Kurt Akamine, *Chair*
Ms. Julie Simonton, *Vice Chair*
Mr. Lawrence Dill
Mr. Elesther Calipjo
Mr. Gregory Kamm
Mr. Troy Tanigawa (*joined @ 10:07 a.m.*)
Mr. Ka`aina Hull (*joined @ 10:19 a.m.*)

Quorum was achieved with 5 members present at Roll Call.

<u>STAFF:</u> (<i>via remote</i>)	Mr. Dustin Moises Mr. Michael Hinazumi Mr. Keith Aoki Mr. Carl Arume Mrs. Jonell Kaohelaulii Board Advisor Steve Kyono Deputy County Attorney Mahealani Krafft	Mr. Valentino Reyna Mr. Claus Bollmann Mr. Marcelino Soliz Mrs. Mary-jane Akuna Mr. Jas Banwait Mrs. Marites Yano
---	--	--

Public Access Line: One person listened in, per IT.

C. ACCEPTANCE OF AGENDA

Mr. Dill moved to approve the Agenda as distributed; seconded by Mr. Kamm; with no objections.

D. MEETING MINUTES

Review and Approval of:

Regular Board Meeting – August 27, 2020

Mr. Dill moved to approve the Regular Board meeting minutes of August 27, 2020; seconded by Ms. Simonton; with no objections, motion carried with 5 ayes.

Review and Approval of:

Executive Session Meeting – August 27, 2020

Mr. Dill moved to approve the Executive Session meeting minutes of August 27, 2020; seconded by Ms. Simonton; with no objections.

E. CORRESPONDENCE/ANNOUNCEMENTS/PUBLIC TESTIMONY

No voice messages or written testimonies received.

Mr. Tanigawa joined the meeting at 10:07 a.m.

F. BOARD COMMITTEE & PERMITTED INTERACTION GROUP REPORTS (PIG)

1. Report of the Permitted Action Group of the Kaua'i County Board of Water Supply

The PIG report was "Received for the Record."

G. OLD BUSINESS

1. Manager's Report No. 20-41 - Waiahi Surface Water Treatment Plant Renovation Construction Cost Progress Report (Update)

No update.

H. NEW BUSINESS

1. Manager's Report No. 21-06 - Discussion and Possible Action on approval of funds for Contract No. 427, Job No. 02-14, WP2020 WK-08 Kapa'a Homesteads 325' Tanks – Two 0.5 Million Gallon (MG) Storage Tanks, Kapa'a, with Belt Collins Hawai'i, LLC in the amount of \$40,978.70

BACKGROUND:

Civil Engineer Mr. Keith Aoki mentioned that this project is in design review and explained that many years ago the funds for the contract were not rolled over to the budget. He requested for the remaining funds for the contract be re-approved by the Board to pay the consultant when invoiced. No additional funds were being requested.

DISCUSSION:

Mr. Dill pointed out on the Manager's Report on Page 23, 3rd paragraph, "Fiscal has started checking with Engineering for Purchase Order (PO) rollovers when the budget of the new year is being prepared." This may be a Fiscal question to identify POs that are rolled over yearly for budget process. He mentioned that Engineering must now track the remaining outstanding rollover balances.

Mr. Dill asked Waterworks Controller Mrs. Yano if Fiscal could track all POs with remaining balances by cross reference check. During the budget process, rollover POs should not be missed. Mrs. Yano responded by saying Fiscal cross checks PO balances in existing contracts but didn't noticed that on the contract terms it expired and the rollover did not happen. According to Engineering, there was a contract extension but instead of letting the contract lapse, the contractor was extended based on Engineering's suspension. As a result, the contract was zeroed out.

At 10:12 a.m., Mr. Kamm lost connection on remote but reconnected.

Chair Akamine called a one minute Recess at 10:14 a.m. to consult with DCA Krafft.

Chair Akamine called the meeting back to order at 10:16 a.m.

Mr. Kamm asked how frequent are rollover cross checks done? Mrs. Yano said the cross checks are done at the end of the year. She agreed to do cross checks more frequently as suggested by Mr. Kamm.

At 10:19 a.m., Mr. Hull joined the meeting.

Mr. Dill moved to approve *pending legal review* Manager's Report No. 21-06 - Discussion and Possible Action on approval of funds for Contract No. 427, Job No. 02-14, WP2020 WK-08 Kapa'a Homesteads 325' Tanks – Two 0.5 Million Gallon (MG) Storage Tanks, Kapa'a, with Belt Collins Hawai'i, LLC in the amount of \$40,978.70; seconded by Ms. Simonton; with no objections, motion carried with 7 ayes, Roll Call: KA, JS, LD, GK, LC, TT, KH

Chair acknowledged members of the public who have logged on the access call in number.

2. Manager's Report No. 21-07 - Discussion and Possible Action on the 7th Amendment to Contract No. 666 to extend the Information Technology Support Services with Brio Consulting, LLC until January 31, 2021 for an additional amount of \$160,000.00

BACKGROUND:

Civil Engineer Mr. Michael Hinazumi requested the Board for approval of \$160,000 for Information Technology (IT) support services on Option 1 on Page 25. IT support services was extended a couple of times pending the interview and selection of a Waterworks IT Manager. The individual who was selected in July declined the position then the Department re-recruited for an IT Manager again. Interviews are tentatively set for next week and during this time, IT support services continues to be needed to service the public. The extension will carry over to January 31, 2021. When the request for funds are made, Mr. Hinazumi will work with legal counsel to fund the contract amendment.

DISCUSSION:

Mr. Hinazumi indicated the beginning of the proposed amendment would start October 1, 2020 (next 4 mos.).

Chair Akamine inquired if the amendment amount of \$160,000 is approved and the new IT Manager has started, would some of the funds not be expended? Mr. Hinazumi said some funds may be used as a cross over to transition the new IT Manager, if not, the additional funds may not be spent.

Mr. Dill moved to amend his motion to approve, *pending legal review* Manager's Report No. 21-07 - Discussion and Possible Action on the 7th Amendment to Contract No. 666 to extend the Information Technology Support Services with Brio Consulting, LLC until January 31, 2021 for an additional amount of \$160,000.00; seconded by Mr. Tanigawa; with no objections, motion carried with 7 ayes, Roll Call: KA, JS, LD, GK, LC, TT, KH

I. CONSENT CALENDAR

1. Manager's Report No. 21-08 - Discussion and Possible Action to approve a Grant of Easement Agreement for Construction Plans for Commercial Site, Kōloa Village, LLC affecting the following:
 - a. Koloa Village, LLC, TMK: (4) 2-8-008:001, Kōloa, Kaua'i, Hawai'i

BACKGROUND:

Chief of Construction Management Mr. Dustin Moises commented that this easement allows the Department to maintain a new waterline.

DISCUSSION:

Mr. Kamm asked if there was a way to locate meters pm public property? Mr. Aoki commented that the contractor installed a Reduced Pressure Detector Assembly (RPDA) that is required on private property within an easement vs. County right of way.

Mr. Kamm moved to approve Manager's Report No. 21-08 - Discussion and Possible Action to approve a Grant of Easement Agreement for Construction Plans for Commercial Site, Kōloa Village, LLC affecting the following: a) Koloa Village, LLC, TMK: (4) 2-8-008:001, Kōloa, Kaua'i, Hawai'i; seconded by Mr. Dill; with no objections, motions carried with 7 ayes, Roll Call: Roll Call: KA, JS, LD, GK, LC, TT, KH

2. Manager's Report No. 21-09 – Discussion and Possible Action to approve a Grant of Easement Agreement for Construction Plans for Lot 114-A-1, TMK: (4) 2-3-012:003, Kalāheo Homesteads affecting the following:
 - a. Guy A. Mechlem, Trustee of the Guy A. Mechlem and Jennifer M. Mechlem Revocable Living Trust dated March 6, 2002
 - b. Jennifer M. Mechlem, Trustee of the Guy A. Mechlem and Jennifer M. Mechlem Revocable Living Trust dated March 6, 2002
 - c. Richard Waalani Jr.
 - d. Michael A. Dahilig
 - e. Brandon S. Tengan and Nikki N. Tengan, husband and wife
 - f. Hanakekela, LLC, a Hawaii limited liability company
 - g. Hoihui, LLC, a Hawaii limited liability company
 - h. Dean S. Marugame and Nilda C. Marugame, husband and wife
 - i. Julius and Gloria Crescines, husband and wife

BACKGROUND:

Mr. Moises indicated there are a cluster of 5/8 inch meters on this lot. The easement is necessary for future maintenance and operations.

Mr. Kamm moved to approved Manager's Report No. 21-09 – Discussion and Possible Action to approve a Grant of Easement Agreement for Construction Plans for Lot 114-A-1, TMK: (4) 2-3-012:003, Kalāheo Homesteads; seconded by Mr. Dill; with no objections, motions carried with 7 ayes, Roll Call: Roll Call: KA, JS, LD, GK, LC, TT, KH

3. Manager's Report No. 21-10 – Discussion and Possible Action to approve a Grant of Easement Agreement for Kulana Subdivision Onsite Water System, Phase I, affecting the following:
 - a. Kulana Association of Apartment Owners, TMK: (4) 4-3-011:001, Kapa‘a, Kaua'i, Hawai'i

BACKGROUND:

Mr. Moises mentioned this decade subdivision restarted in 2018 and Phase 1 is nearing completion for onsite water facilities. The new roadway will not be conveyed to the County and in order for the Department to maintain the facilities, the County has to provide an easement throughout all private roadways.

Mr. Kamm moved to approve Manager's Report No. 21-10 – Discussion and Possible Action to approve a Grant of Easement Agreement for Kulana Subdivision Onsite Water System, Phase I, affecting the following: a) Kulana Association of Apartment Owners, TMK: (4) 4-3-011:001, Kapa‘a, Kaua'i, Hawai'i, seconded by Dill; with no objections, motions carried with 7 ayes, Roll Call: Roll Call: KA, JS, LD, GK, LC, TT, KH

4. Manager's Report No. 21-11 – Discussion and Possible Action to approve the Conveyance of Water Facility from Kulana Association of Apartment Owners, for the Kulana Subdivision Onsite Water System, Phase I, TMK: (4) 4-3-011:001, Kapa‘a, Kaua'i, Hawai'i

BACKGROUND:

Mr. Moises commented that since the Conveyance of Water Facility is more than \$500,000, per Board Policy No. 24, this requires a Manager's Report. This recognizes developers who convey a large amounts to the Department.

Mr. Kamm moved to approve Manager's Report No. 21-11 – Discussion and Possible Action to approve the Conveyance of Water Facility from Kulana Association of Apartment Owners, for the Kulana Subdivision Onsite Water System, Phase I, TMK: (4) 4-3-011:001, Kapa‘a, Kaua'i, Hawai'i, seconded by Mr. Dill; with no objections, motions carried with 7 ayes, Roll Call: Roll Call: KA, JS, LD, GK, LC, TT, KH

J. STAFF REPORTS MONTHLY

1. Discussion and Receipt of the Kaua'i County Water Department's Statement of Revenues and Expenditures
 - a. August Monthly Summary Budget
 - b. Accounts Receivable Aging Summary

BACKGROUND:

Waterworks Controller Mrs. Marites Yano referenced the Billed Revenues Comparative Chart, Page 122. The accumulative billed revenues is \$682,862. Cash Receipts was down by \$3M and Mrs. Yano explained that at the same time last year, the Department received a \$2.2M State grant that resulted in a decrease in cash receipts. Metered Consumption, Page 124 – is the decrease for the month, 66M gallons YTD. YTD Metered Consumption, Page 125 showed a cumulative decrease of 97M gallons. Monthly Budget Summary vs. Actual, Page 114 – Water sales is up by \$875,371 YTD due to conservative revenue projections.

Collection efforts with island utilities during the pandemic – Fiscal reached out to Board of Water Supply, County of Maui, County of Hawai'i and Honolulu Board of Water Supply who are suspending all collection efforts until December 31, 2020. The Department of Water will also suspend collections until the end of the year.

DISCUSSION:

DOW does not need a policy to suspend collections until December 31st because this is only temporary according to Mrs. Yano. The collection efforts are already in the Rules & Regulations.

Received for the Record

2. Discussion and Receipt of the Report by the Information & Education Specialist on Public Relations Activities

BACKGROUND:

Information & Education Specialist Mrs. Jonell Kaohelaulii provide the following highlights:

1. PR continues to support customer service efforts during the COVID related closures through social media, revised internal procedures for public notices and Black Board Connect. PR supports all divisions with customer relations and public service announcements.
2. Increasing education and community outreach efforts - Next community outreach is Water Education Today (WET) is the kit distribution event for keiki on Tuesday, October 6th 9 am to 10 am at the Vidinha Stadium parking lot. This is a drive through event and open to the public. Volunteers are needed especially the Board to assist in distributing 700 water education kits to the public. This is part of the Department's Imagine a Day without Water campaign held in October.
3. PR is developing a Facebook campaign for the Department and joining thousands of water agencies across the nation to educate local communities about the value of water. PR is co-leading the state-wide effort with the sister water departments to host Facebook campaigns.
4. PR is hosting a hashtag value water challenge on Facebook to encourage the community the question: Why is water important to you? Water and water infrastructure to provide water service should not be taken for granted. Community member interviews will be scheduled to share their water story on this campaign.
5. Project WET Hawai'i on line Trainings – County and State agencies will be continuing training on line.
6. Fourth Quarter – PR will work on its first visual workshop for an educator and facilitator trainings on January 2021.

Received for the Record

3. Discussion and Receipt of the Chief of Operation's Summary Report on Operational Activities

BACKGROUND:

Mr. Valentino Reyna highlighted the following:

1. Personnel – Christopher Caoagas was promoted from Groundskeeper to Utility worker.
2. Certified Flagger training and Respiratory Safety Class & Fit testing was attended by Operations staff.

Discussion:

Industry Standard in Water Loss (gallons per day) – Mr. Dill requested Mr. Reyna to compare the industry standard on water loss with other county departments and to update the Board in the next Operations report. Currently Operations is within the industry standard of 15%.

Mr. Reyna provided an update on the backflow preventer leak at Aloha Church – The leak has been ongoing for a month. The Operations Superintendent visited the site to inform Aloha Church they are the owner responsible to do the repairs. The owners are waiting to receive the parts to be repaired by a licensed contractor. The leak is before the meter on their side of assembly. DCA Krafft indicated that the Department has the authority to make repairs if an owner does not respond and to charge the customer. Mr. Reyna credited Mrs. Yano and Mr. Soliz for persuading the owner to act on the repair.

Received for the Record

4. Discussion and Receipt of the Manager and Chief Engineer's Monthly Update Regarding Activities of Note of the DOW

Chair Akamine highlighted the following:

1. Contacts Awarded/Extension/Amendments – Contract No. 533, Contract No. 698, Contract 702, and Contract 703,
2. Personnel Matters – Recruitment continues for several open positions.
3. Board Advisor's Report – Mr. Steve Kyono continues to assist the Board and Department on operations.
4. Waimea Huakai Subdivision Project – There were potential delays but the Department worked with the contractor to get requirements in place by September 1st (affordable housing; 31 units, 800 applicants).

Received for the Record

At 10:47 a.m. Mr. Hull read the Executive Session language.

Mr. Hull moved to go into Executive Session and to invite Mr. Robert O'Brien and Waterworks Controller Mrs. Marites Yano for K #2 as resources and to adjourn after Executive Session; seconded by Ms. Simonton; with no objections.

K. EXECUTIVE SESSION

Pursuant to Hawai'i Revised Statutes(HRS) §92-7(a), the Board may, when deemed necessary, hold an executive session on any agenda item without written public notice if the Executive Session was not anticipated in advance. Any such executive session shall be held pursuant to HRS §92-4 and shall be limited to those items described in HRS §92-5(a).

1. Pursuant to Hawai'i Revised Statutes § 92-4 and § 92-5(a)(2), the purpose of this Executive Session is for the Board to consider the discipline of an officer or employee or of charges brought against the officer or employee, where consideration of matters affecting privacy will be involved; provided that if the individual concerned requests an open meeting, an open meeting shall be held.
2. Pursuant to Hawai'i Revised Statutes § 92-4 and § 92-5(a)(4), the purpose of this Executive Session is for the Board to consult with the Board's attorney on questions and issues pertaining to the Board's powers, duties, privileges, immunities, and liabilities as it relates to Manager's Report No. 20-53 Discussion and Possible Action on correspondence from Grove Farm regarding Grove Farm's Request for Revenue Requirement Shortfall (*Update*)

Board approved to enter into negotiations with Grove Farm to resolve this matter and will demonstrate the Board's good faith effort to Grove Farm to resolve this matter.

K. TOPICS FOR NEXT BOARD OF WATER SUPPLY MEETING (October 2020)

1. Manager's Report No. 19-47 - Discussion and Possible Action for Board Approval to enter into the First Amendment to the Memorandum of Agreement between the Department of Public Works, County of Kaua'i and the Board of Water Supply, County of Kaua'i for the County's Kahiliholo Road Culvert Repair Project and expenditure of funds in the amount of \$44,100.00 (*Update*)
2. Manager's Report No. 19-60 - Discussion and Possible Action for Water Plan 2020 Project No. WK-39 Drill & Develop Kapa'a Homesteads Well No. 4 & Package A-Well and Drainage Package of Water Plan 2020 Project No. WK-08, Job No. 02-14, Kapa'a Homesteads 325' Tanks, Two 0.5 MG Tanks Projects, Kapa'a, Kaua'i, Hawai'i for additional construction funding in the amount of \$150,311.48 and 298 calendar day time extension for proposed Change Order #14 (*Update*)

L. TOPICS FUTURE BOARD OF WATER SUPPLY MEETINGS

1. Department of Water Performance Audit (*Update*)
2. Table of Organization Workshop
3. Discussion and Possible Action to establish Fiscal Policies and Procedures
4. Manager's Report No. 20-51 – Discussion and Possible Action regarding the communication from the Salary Commission requesting for the Board's opinion on the challenges that the Board is facing while hiring a Manager & Chief Engineer (*Update*)
5. Baseyard Master Plan Workshop
6. Discussion and Receipt of the Department of Water's Draft Audit Financial Statements and Independent Auditor's Report by Accuity, Inc. for Fiscal Year 2020 and 2019 (November 2020)
7. Election of Officers for 2021 (November 2020)
8. Board Meeting Dates for 2021 (November 2020)

M. UPCOMING EVENTS

N. NEXT WATER BOARD MEETING

1. Thursday, October 22, 2020, 10:00 a.m.
2. Thursday, November 19, 2020, 10:00 a.m.
3. Thursday, December 17, 2020, 10:00 a.m.
4. Thursday, December 21, 2020, 10:00 a.m.

O. ADJOURNMENT

Chair Akamine adjourned the meeting after Executive Session at 11:49 p.m. with no objections.

Respectfully submitted,

Approved,

Edith Ignacio Neumiller
Commission Support Clerk

Elesther Calipjo
Secretary, Board of Water Supply

SPECIAL BOARD MEETING MINUTES
BOARD OF WATER SUPPLY
Friday, September 18, 2020

The Board of Water, County of Kaua'i, met in a special meeting via remote in Lihu'e on Friday, September 18, 2020. Chair Kurt Akamine called the meeting to order at 9:03 a.m.

BOARD: Mr. Kurt Akamine, *Board Chair*
Ms. Julie Simonton
Mr. Ka`aina Hull
Mr. Lawrence Dill
Mr. Elesther Calipjo
Mr. Greg Kamm

EXCUSED: Mr. Troy Tanigawa

Quorum was achieved with 6 members present at Roll Call.

STAFF: Mr. Valentino Reyna Mr. Michael Hinazumi
Mr. Bryan Wienand Mrs. Mary-jane Akuna
DCA Mahealani Krafft Mr. Jas Banwait

Commission Support Clerk reported there were no written or phone message testimonies received.

C. MEETING MINUTES
None.

D. OLD BUSINESS
None.

E. NEW BUSINESS
1. Discussion and Possible Action on the hiring of an Interim Manager and Chief Engineer

At 9:07 a.m., Mr. Dill read the Executive Session language.

Mr. Dill moved to go into Executive Session then to adjourn the meeting; Mr. Kamm seconded; with no objections, motion carried with 5 ayes.

F. EXECUTIVE SESSION
Pursuant to Hawai'i Revised Statutes § 92-4 and § 92-5(a)(2) and (4), the purpose of this Executive Session is for the Board to consider the hiring of an interim manager and chief engineer where consideration of matters affecting privacy will be involved; provided that if the individual concerned requests an open meeting, an open meeting shall be held; and for the Board to consult with the Board's attorney on questions and issues pertaining to the Board's powers, duties, privileges, immunities, and liabilities.

G. ADJOURNMENT

Respectfully submitted,

Edith Ignacio Neumiller
Commission Support Clerk

Approved,

Elesther Calipjo
Secretary, Board of Water Supply

**SPECIAL BOARD MEETING MINUTES
BOARD OF WATER SUPPLY
Thursday, September 24, 2020**

The Board of Water, County of Kaua'i, met in a special meeting via remote in Līhu'e on Thursday, September 24, 2020. Chair Kurt Akamine called the meeting to order at 12:00 p.m.

BOARD: Mr. Kurt Akamine, *Board Chair*
Ms. Julie Simonton
Mr. Ka`aina Hull
Mr. Lawrence Dill
Mr. Troy Tanigawa
Mr. Greg Kamm

EXCUSED: Mr. Elesther Calipjo

Quorum was achieved with 6 members present at Roll Call.

STAFF: Mr. Steve Kyono, Board Advisor Mr. Marcelino Soliz
Mr. Mike Hinazumi Mr. Jas Banwait
DCA Mahealani Krafft Mr. Jas Banwait

Commission Support Clerk reported there were no written or phone message testimonies received.

C. MEETING MINUTES
None.

D. OLD BUSINESS
None.

E. NEW BUSINESS

1. Discussion and Possible Action on the hiring of an Interim Manager and Chief Engineer

Mr. Kamm read the Executive Session language.

Mr. Kamm moved to go into Executive Session & then to adjourn the meeting; Mr. Dill seconded; with no objections, motion carried with 6 ayes.

F. EXECUTIVE SESSION

Pursuant to Hawai'i Revised Statutes § 92-4 and § 92-5(a)(2) and (4), the purpose of this Executive Session is for the Board to consider the hiring of an interim manager and chief engineer where consideration of matters affecting privacy will be involved; provided that if the individual concerned requests an open meeting, an open meeting shall be held; and for the Board to consult with the Board's attorney on questions and issues pertaining to the Board's powers, duties, privileges, immunities, and liabilities.

Mr. Hull moved to approve the appointment of Mr. Mark Knoff as Interim Manager & Chief Engineer and to offer the full salary amount and for the Chair to allow the division heads to meet Mr. Knoff and to move forward for the appointment; seconded by Mr. Dill; with no objections motions carried with 6 ayes, Roll Call KA, JS, KH, LD, GK, TT

G. ADJOURNMENT

Chair Akamine adjourned the meeting after Executive Session at 12:36 p.m. with no objections.

Respectfully submitted,

Approved,

Edith Ignacio Neumiller
Commission Support Clerk

Elesther Calipjo
Secretary, Board of Water Supply

Correspondence

RECEIVED



Katrina C. Medina
RS 73797
Senior Real Estate Manager

CBRE, Inc.
Property Management

2020 SEP 25 PM 1:11

DEPARTMENT OF WATER
COUNTY OF KAUAI

1003 Bishop St
Suite 1800
Honolulu, HI 96813-6457

808 541 5115 Tel
808 541 5155 Fax
808 397 0074 Cell

katrina.medina2@cbre.com
www.cbre.com

September 21, 2020

Board Members- Department of Water Supply
4398 Pua Loke Street
Lihue, HI 96766

RE: Plumbing Code Amendment Requiring Installation of Back Flow Preventors

Dear Mr. Akamine, Chairman, and Fellow Board Members

As you are aware, COVID 19 has wreaked economic and personal hardship on everyone. No one would have predicted the nature and extent of the losses. The retail sector has been hit particularly hard and the tenants and owner of Kauai Village are experiencing the same adversities as everyone else.

Unfortunately, some tenants have been forced to close, while others seek assistance for any support source possible including from ownership. Ownership also has financial and lease obligations and is struggling to adapt and survive. However, we are committed to working closely with our tenants doing our part to support them in this critical time of need.

We are also fully committed to the Kauai community and to this investment. We recently completed façade renovations and repairs to the parking lots. These capital investments were in excess of \$X.XX and resulted in an improved overall look and experience for our customers. We are very fortunate to have signed new tenants including Hawaii Pacific Health which recently opened a medical clinic to serve the residents of East Kauai. Other recently signed tenants remain committed to opening their businesses. However, these tenants seeking building permits have been informed by DOW that no permits will be issued until the Village installs a back flow preventor for the fire suppression line.

Kauai Village was constructed in 1989. It was built in accordance with the approved plans and then applicable codes. The Village consists of a 6” domestic water line, providing water service to the tenants. Additionally, there is an isolated 8” fire protection water line, with a total of five risers, each constructed with a check valve assembly and an 8” Detector Check Valve and Meter. This is an effectively “closed system.” Lastly, there is an irrigation water line. Both the 6” domestic water line and the 2” irrigation water line have their own reduced pressure back flow preventors. We have attached copies of the approved plan sheets supporting the above information.

We understand the recent objective to gain compliance with the code amendment. We also understand that certain property owners may not be compliant. However, given the information above, are asking for your consideration and some timing flexibility with this unexpected and expensive retrofit of the fire suppression water system. As a result, we propose the following:

Kauai Village shall immediately undertake and complete the design drawings for a back flow preventor of the fire suppression line and will submit the plans from a Hawaii Mechanical Engineer within 90 days of

approval of our request. We ask for a three-year period from time of plan approval to construct and install the back flow preventor. This will provide ownership with time to get through the worst of the economic crisis, support our tenants, invest into tenant improvements, prepare bid documents, select a contractor, and perform the work.

We appreciate your consideration of our request and hope that we can reach an equitable resolution. The above proposal demonstrates our commitment to comply with the requirement and affords us the time needed to steer through this difficult period. Please don't hesitate to contact me should you wish to discuss further.

EREP Kauai Village II LLC

By: CBRE, Inc.
Its authorized manager

A handwritten signature in black ink, appearing to read 'Katrina', with a long, sweeping horizontal stroke extending to the right.

Katrina C. Medina

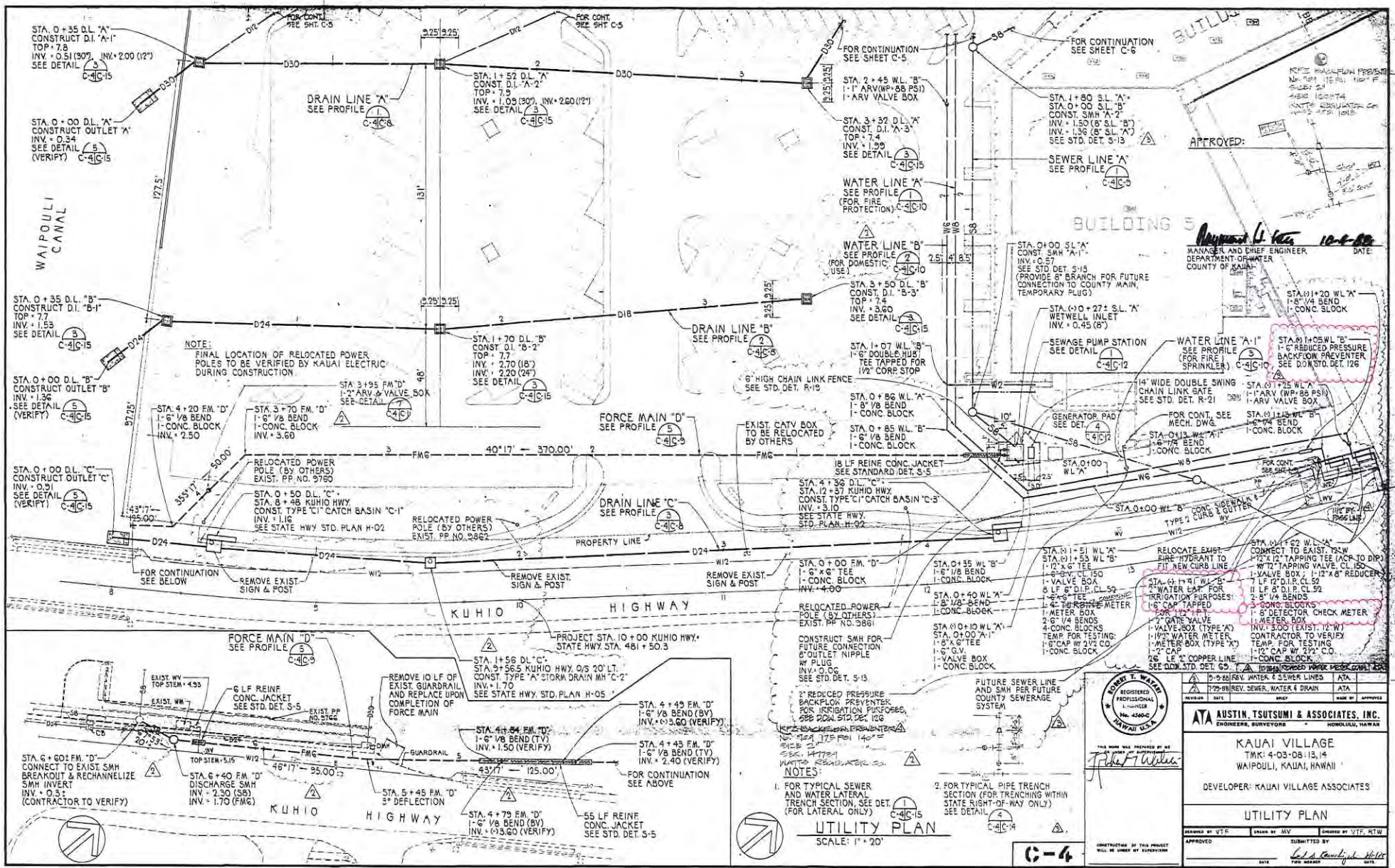

APPROVED: *Harold L. Kee* 10-4-80
 MANAGER AND CHIEF ENGINEER
 DEPARTMENT OF WATER
 COUNTY OF KAUAI



ATA AUSTIN, TSUTSUMI & ASSOCIATES, INC. ENGINEERS, SURVEYORS HONOLULU, HAWAII	
KAUAI VILLAGE TMR: 4-03-08 13, 14 WAIPOULI, KAUAI, HAWAII DEVELOPER: KAUAI VILLAGE ASSOCIATES	
UTILITY PLAN	
DESIGNED BY: UTE APPROVED: <i>Robert F. Wilcox</i>	DRAWN BY: JLV CHECKED BY: UTE, RTW SUBMITTED BY: <i>Robert F. Wilcox</i>
DATE: _____ FILE NO.: _____	DATE: _____ FILE NO.: _____

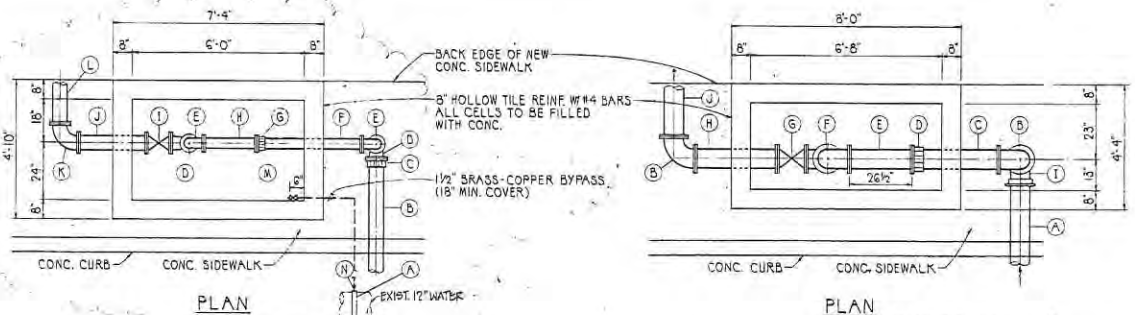

PLAN

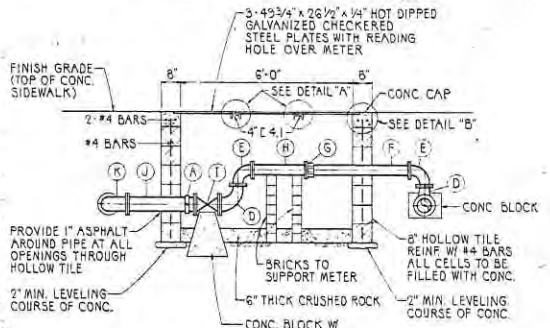

SECTION

4" TURBINE METER DETAIL
SCALE: 1/2" = 1'-0"

SCHEDULE OF VALVES AND FITTINGS - 4" COMPOUND METER	
ITEM	DESCRIPTION
(A)	6" SERVICE SADDLE W/ 1/4" C.C. TAP
(B)	6" D.I. PIPE, CL. 52, FE x MJ
(C)	8" FLANGED COUPLING ADAPTER W/ RETAINER GLANDS
(D)	6" x 4" REDUCING 1/4 D.I. BEND, FE
(E)	4" 1/4 D.I. BEND, FE
(F)	4" D.I. NIPPLE, FE x FE, 3'-0" LONG
(G)	4" FLANGED COUPLING ADAPTER
(H)	8" x 26 1/2" LONG SPOOL, FE, PLUGGED AT EA. END (CONTRACTOR FURNISH & INSTALL)
(I)	6" GATE VALVE, FE W/ HANDWHEEL
(J)	6" D.I. NIPPLE, FE
(K)	6" 1/4 D.I. BEND, FE
(L)	6" D.I. PIPE, CL. 52, FE x MJ
(M)	1/2" STOP COCK W/ PLUG
(N)	1/4" C.C. x 1/2" M.P.T. CORP. COCK W/ CAP

NOTE: DOW. TO INSTALL 4" TURBINE METER AND STRAINER

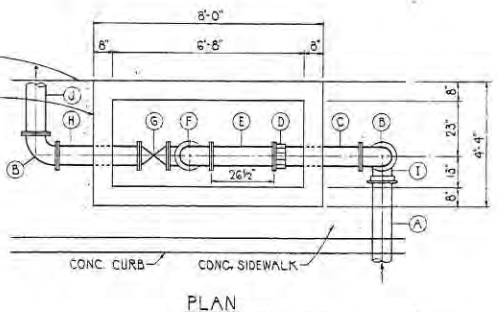

PLAN

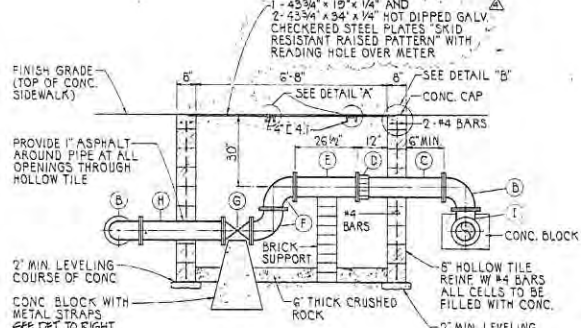

SECTION

8" DETECTOR CHECK METER DETAIL
SCALE: 1/2" = 1'-0"

SCHEDULE OF VALVES AND FITTINGS - 8" D.C. METER	
ITEM	DESCRIPTION
(A)	8" D.I. PIPE, CL. 52, MJ
(B)	8" 1/4 D.I. BEND, FE
(C)	8" D.I. NIPPLE, FE x FE, 3'-0" LONG
(D)	8" FLANGED COUPLING ADAPTER
(E)	8" x 26 1/2" LONG SPOOL, FE, PLUGGED AT EACH END (CONTRACTOR TO FURNISH & INSTALL)
(F)	8" 1/4 D.I. BEND, FE
(G)	8" GATE VALVE, FE W/ HANDWHEEL
(H)	8" D.I. NIPPLE, FE
(I)	8" 1/4 D.I. BEND, FE x MJ
(J)	8" D.I. PIPE, FE x MJ

NOTE: DOW. TO INSTALL 8" DETECTOR CHECK METER.

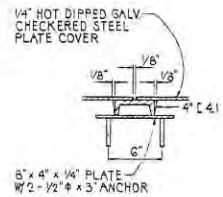

DETAIL "A"
NOT TO SCALE

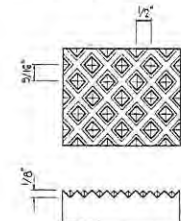

RAISED SURFACE DETAIL
NOT TO SCALE

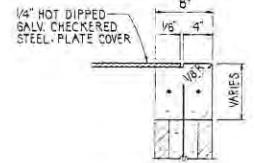

DETAIL "B"
NOT TO SCALE

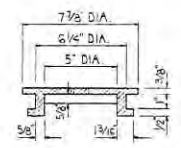
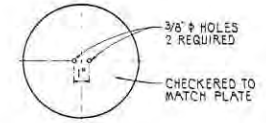

CAST IRON READING-HOLE COVER DETAIL
NOT TO SCALE



READING-HOLE COVER FRAME DETAIL
NOT TO SCALE

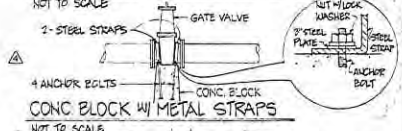

CONC. BLOCK W/ METAL STRAPS
NOT TO SCALE

APPROVED:
Richard H. Goss
MANAGER AND CHIEF ENGINEER
DEPARTMENT OF WATER
COUNTY OF KAUAI
10-6-88
DATE



REVISION	DATE	BY	DATE	APPROVED
1				
2				

ATA AUSTIN, TSUTSUMI & ASSOCIATES, INC.
ENGINEERS, SURVEYORS 7 HONOLULU, HAWAII

KAUAI VILLAGE
TRK. 4-03-08-13, 14
WAIPOULI, KAUAI, HAWAII

DEVELOPER: KAUAI VILLAGE ASSOCIATES

WATER METER DETAILS

DESIGNED BY	DRWN BY	CHECKED BY	DATE
30	30	30	10/6/88



CONSTRUCTION OF THIS PROJECT
WILL BE UNDER MY SUPERVISION

SHEET	OF	FILE	PRICE	TOLDS	NO.

George Michael Barker [REDACTED]

TO: Dept. Of WATER(WATER has NO substitute, Conserve It being the MOTTO) Lihue Kauai,Hawaii 96766

Between 11 Oct. 2019 and 18 Oct. 2019, my helghbor ,Gwen [REDACTED]

[REDACTED] noticed a fresh water leak on her property near the road. She called the Water Dept. twice. The 2nd time, the Water Dept. spokesperson said someone from the Water Dept. would be sent out to look at it. Gwen Saiki has requested to me to ADVISE a Manager or Supervisor to call her at 823-8422 and she will give a statement to that person. She will then sign it. NO ONE from the Water Dept . ever came out.

75,000 GALLONS later and a \$698.00 Dollar water bill, I am protesting and disputing my Water bill charge. The Water Dept. had a JOB and a responsibility to respond, they failed to do so.

My Water bills over the last 9 months have been \$ 17.75 six months in a row, a \$21 dollar bill, a \$26.00 bill and the Sept. 2019 bill of \$45.80. I will pay equivalent to my last bill of \$45.80 on this latest bill. The Water Dept. is at fault here. Please issue a credit for the remaining balance. Again, please call gwen Saiki @ 823-8422 for her over the phone statement to you. Once you put her statement into writing, please give it to her or mail it to her. She will then sign it.

Sincerely, George Michael Barker

George Michael Barker
13 NOV. 2019

RECEIVED

788 SEP 21 AM 11:06

DEPARTMENT OF WATER

GEORGE MICHAEL BARKER

RECEIVED

2020 SEP 21 AM 11:06

DEPARTMENT OF WATER SUPPLY

{ water valve located @
Gwen [redacted]
[redacted] Kaapuni Road
KAPAA, KAUAI, HAWAII 9674
Account # [redacted]
my phone: [redacted] }

BACK in OCTOBER 2019, between the 11th & 18th of OCTOBER, 2019, a 75,000 Gallon LEAK 2 feet from the Kaapuni Road and 200 feet from my house occurred. No one told me until 8 or 9 days later. My neighbor Gwen Saini, where the water valve is located, called in the leak to the Water Dept. on Day 2 and Day 5.

A spokesperson for the water Dept. said the water Dept. would go out and look at it. No one from the Water Dept. ever came out to look at it. I shut the valve (water) off 8 or 9 days later. Gwen Saini witnessed me shut the water valve.

Please call Gwen Saini @ 823-8422 as she has asked me AND the water Dept. already that she will give you a statement over the phone to you, you can print it out, and she will then sign it.

The water Dept. failed in their job; responsibility to look at this leak and made no attempt to contact homeowner's in the area that it might be their water line with a large leak.

My account was closed in Feb. 2020 for non-payment. I have had no water since Feb. 2020.

Please issue a credit for \$650-\$680, whatever is due. Please re-activate my "old account" if possible, and schedule a time & date to turn the water back on. Please waive any "turn on water fee" or charge as a gesture of good will. I have paid every bill & been a loyal customer for 20 years. Please call me @ [redacted] with your decision & a date & time to turn the water back on.

DEPARTMENT OF WATER
COUNTY OF KAUAI
4398 Pua Loke St.
Lihue, HI 96766

Water has no substitute...Conserve It!

RECEIVED

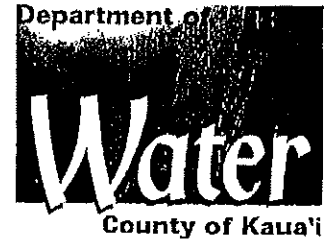

11/21/2019

2019-11-21 AM 11:06

DEPARTMENT OF WATER
COUNTY OF KAUAI

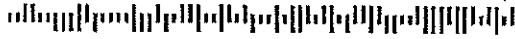

0126019-HBKL140170-LT.1GRP-57

BARKER, GEORGE M



PAST DUE NOTICE

Aloha BARKER, GEORGE M,

This is a friendly reminder that, as of 11/21/2019, we have not received your payment in the amount of \$649.40 on account [REDACTED]. As you know, payment is due within twenty (20) days of the bill, and a 0.5% late fee is added to your bill if the past due amount is not paid within thirty (30) days.

Please make your check or money order payable to: Department of Water. **Credit or Debit Cards are not accepted.**

If you are experiencing difficulty in making your payments and would like to discuss payment options, or have any questions regarding your past due amount, please visit our billing office at the Department of Water or contact us by phone during our hours of operation listed below:

Billing & Customer Service Hours (Walk-in payments & service windows):

Monday - Friday 8:00 a.m. to 4:00 p.m., *except holidays*

Business Hours (available by phone):

Monday - Friday 7:45 a.m. to 4:30 p.m., *except holidays*

To assist our customers with convenient payment options, we also offer an automatic bill payment service online at www.kauaiwater.org where you may also opt to receive electronic billing statements.

If you have already sent your payment, please disregard this notice and accept our thanks. However, if you have not yet made a payment, kindly do so immediately to avoid termination of water service and further collection action.

Your prompt attention is greatly appreciated.

Mahalo,

Billing & Collections
Department of Water, County of Kauai



DEPARTMENT OF WATER
COUNTY OF KAUAI
4398 Pua Loke St.
Lihue, HI 96766

Water has no substitute... Conserve It!

RECEIVED

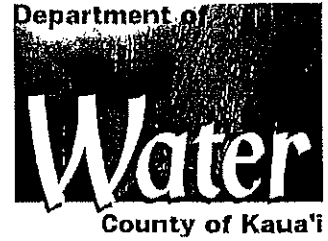

12/06/2019

2019 DEC 21 11:06

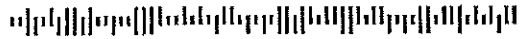

0126776-HBKL141108-LT.1GRP-4

GEORGE M BARKER

Re: Service at: [REDACTED]

Dear Customer and/or Tenant:

As of 12/06/2019, we have not received payment and your account [REDACTED] is now past due.

If we do not receive payment in full by 12/16/2019, your water service will be discontinued for nonpayment. If service is discontinued you will be subject to a new service deposit and a reconnection charge in addition to the unpaid amount.

If you are a tenant, you can either remit payment in full or put service in your name. If you put service in your name, you will be responsible for charges going forward.

Please call us at 808-245-5430 before 12/16/2019 to discuss how we can resolve this matter.

Sincerely,

Customer Service Section

1/1

00000000

CM-FINAL-K

PAGE 24

GEORGE MICHAEL BARKER



7020 1290 0000 2546 2853



1000

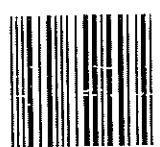

96766

U.S. F
FCM
LIHUE
96766
SEP 1
AMOL
\$
R2304

Kapaa Hawaii 96746

[* Actual ^{water} value location 5585
Gwen 
(By the street)

RETURN RECEIPT
REQUESTED

RECEIVED

2021 SEP 21 AM 11:07

LIHUE, HI 96766

RETURN RECEIPT
REQUESTED

DEPARTMENT OF WATER - KAWAI
ATTENTION: "APPOINTED" MR. GREG KAMM
"APPOINTED CHAIR" MR. KURT AKAMI
4398 PUA LOKE STREET
LIHUE, KAWAI, HAWAII
* 96766 *

Attention: SENIOR Management
* BARKER *

My attempts:

GEORGE MICHAEL BARKER

- 1) Certified Letter to Greg Kama
9 days ago: NO RESPONSE
- 2) Certified Letter to Kurt Akamine
9 days ago NO RESPONSE
- 3) Three phone messages to
Christina Agarina NO RESPONSE

RECEIVED
 { water valve located @
 Gwen Saini property by street }
 [REDACTED]

Public 30 AM 11:52
 RELATIONS
 ACCOUNT # [REDACTED]
 My phone: [REDACTED]
 TUES. 29 SEPT. 2020
 DEPARTMENT OF WATER
 COUNTY OF KAUAI

I am a Retired military Veteran!!
 BACK in OCTOBER 2019, between the 11th & 18th of OCTOBER, 2019, a 75,000 Gallon LEAK 2 feet from the Kaupuni Road and 200 feet from my house occurred. No one told me until 8 or 9 days later. My neighbor Gwen Saini, where the water valve is located, called in the leak to the water Dept. on Day 2 and Day 5.

A spokesperson for the water Dept. said the water Dept. would go out and look at it. No one from the water Dept. ever came out to look at it. I shut the valve (water) off 8 or 9 days later. Gwen Saini witnessed me shut the water valve.

Please call Gwen Saini @ [REDACTED] as she has asked me AND the water Dept. already that she will give you a statement over the phone to you, you can print it out, and she will then sign it.

The water Dept. failed in their job & responsibility to look at this leak and made no attempt to contact homeowner's in the area that it might be their water line with a large leak.

My account was closed in Feb. 2020 for non-payment. I have had no water since Feb. 2020. Please issue a credit for \$650. \$680, whatever is due. Please re-activate my "old account" if possible and schedule a time & date to turn the water back on. Please waive any "turn on water fee" or charge as a gesture of good will. I have paid every bill & been a loyal customer for 20 years. Please call me @ [REDACTED] with your decision & a date & time to turn the water back on. Thank you, George Michael Barker

George Michael Barker, [REDACTED]

TO: Dept. Of WATER(WATER has NO substitute, Conserve it being the MOTTO) Lihue Kauai,Hawaii 96766

Between 11 Oct. 2019 and 18 Oct. 2019, my neighbor ,Gwen [REDACTED] ,Kauai,Hawaii 96746 Phone [REDACTED] noticed a fresh water leak on her property near the road. She called the Water Dept. twice. The 2nd time, the Water Dept. spokesperson said someone from the Water Dept. would be sent out to look at it. Gwen Saiki has requested to me to ADVISE a Manager or Supervisor to call her at [REDACTED] and she will give a statement to that person. She will then sign it. NO ONE from the Water Dept . ever came out.

75,000 GALLONS later and a \$698.00 Dollar water bill, I am protesting and disputing my Water bill charge. The Water Dept. had a JOB and a responsibility to respond, they failed to do so.

My Water bills over the last 9 months have been \$ 17.75 six months in a row, a \$21 dollar bill, a \$26.00 bill and the Sept. 2019 bill of \$45.80. I will pay equivalent to my last bill of \$45.80 on this latest bill.The Water Dept. is at fault here. Please issue a credit for the remaining balance. Again, please call gwen Saiki @ 823-8422 for her over the phone statement to you. Once you put her statement into writing, please give it to her or mail it to her.She will then sign it.

Sincerely, George Michael Barker

George Michael Barker
13 NOV. 2019

DEPARTMENT OF WATER
COUNTY OF KAUAI
4398 Pua Loke St.
Lihue, HI 96766

Water has no substitute... Conserve It!



12/06/2019



0125776-HBKL141168-LT.1GRP-4

GEORGE M BARKER



Re: Service at: 5599 KAAPUNI RD

Dear Customer and/or Tenant:

As of 12/06/2019, we have not received payment and your account [REDACTED] is now past due.

If we do not receive payment in full by 12/16/2019, your water service will be discontinued for nonpayment. If service is discontinued you will be subject to a new service deposit and a reconnection charge in addition to the unpaid amount.

If you are a tenant, you can either remit payment in full or put service in your name. If you put service in your name, you will be responsible for charges going forward.

Please call us at 808-245-5430 before 12/16/2019 to discuss how we can resolve this matter.

Sincerely,

Customer Service Section



00000000

DEPARTMENT OF WATER
COUNTY OF KAUAI
4398 Pua Loke St.
Lihue, HI 96766

Water has no substitute... Conserve It!



11/21/2019



0125019-HBKL140170-LT.1GRP-57

BARKER, GEORGE M



PAST DUE NOTICE

Aloha BARKER, GEORGE M,

This is a friendly reminder that, as of 11/21/2019, we have not received your payment in the amount of \$649.40 on account [REDACTED]. As you know, payment is due within twenty (20) days of the bill, and a 0.5% late fee is added to your bill if the past due amount is not paid within thirty (30) days.

Please make your check or money order payable to: Department of Water. **Credit or Debit Cards are not accepted.**

If you are experiencing difficulty in making your payments and would like to discuss payment options, or have any questions regarding your past due amount, please visit our billing office at the Department of Water or contact us by phone during our hours of operation listed below:

Billing & Customer Service Hours (Walk-in payments & service windows):

Monday - Friday 8:00 a.m. to 4:00 p.m., *except holidays*

Business Hours (available by phone):

Monday - Friday 7:45 a.m. to 4:30 p.m., *except holidays*

To assist our customers with convenient payment options, we also offer an automatic bill payment service online at www.kauaiwater.org where you may also opt to receive electronic billing statements.

If you have already sent your payment, please disregard this notice and accept our thanks. However, if you have not yet made a payment, kindly do so immediately to avoid termination of water service and further collection action.

Your prompt attention is greatly appreciated.

Mahalo,

Billing & Collections
Department of Water, County of Kauai



SENDER: COMPLETE THIS SECTION	COMPLETE THIS SECTION ON DELIVERY
<ul style="list-style-type: none"> Complete items 1, 2, and 3. Print your name and address on the reverse so that we can return the card to you. Attach this card to the back of the mailpiece, or on the front if space permits. 	<p>A. Signature  <input type="checkbox"/> Agent <input type="checkbox"/> Addressee</p> <p>B. Received by (Printed Name) <u>Betta Dee Malapit</u> C. Date of Delivery <u>09.21.20</u></p>
<p>1. Article Addressed to:</p> <p><u>Dept. of water, Kauai</u> <u>Attn. Mr. Greg Kamon &</u> <u>or Mr. Kurt Akamine</u> <u>4399 Pua Loke St</u> <u>Lihue Kauai, Hawaii 96766</u></p>  <p>9590 9402 5678 9346 2965 40</p>	<p>D. Is delivery address different from item 1? <input type="checkbox"/> Yes If YES, enter delivery address below: <input type="checkbox"/> No</p>
<p>2. Article Number (Transfer from service label)</p> <p><u>7020 1290 0000 2546 2853</u></p>	<p>3. Service Type</p> <ul style="list-style-type: none"> <input type="checkbox"/> Adult Signature <input type="checkbox"/> Adult Signature Restricted Delivery <input type="checkbox"/> Certified Mail® <input type="checkbox"/> Certified Mail Restricted Delivery <input type="checkbox"/> Collect on Delivery <input type="checkbox"/> Collect on Delivery Restricted Delivery <input type="checkbox"/> Insured Mail <input type="checkbox"/> Insured Mail Restricted Delivery (over \$500) <input type="checkbox"/> Priority Mail Express® <input type="checkbox"/> Registered Mail™ <input type="checkbox"/> Registered Mail Restricted Delivery <input type="checkbox"/> Return Receipt for Merchandise <input type="checkbox"/> Signature Confirmation™ <input type="checkbox"/> Signature Confirmation Restricted Delivery

PS Form 3811, July 2015 PSN 7530-02-000-9053

Domestic Return Receipt

U.S. Postal Service™
CERTIFIED MAIL® RECEIPT
Domestic Mail Only

For delivery information, visit our website at www.usps.com®.

Lihue, HI 96766

OFFICIAL USE

Certified Mail Fee	\$3.55
Extra Services & Fees (check box, add fee as appropriate)	\$7.85
<input type="checkbox"/> Return Receipt (hardcopy)	\$0.00
<input type="checkbox"/> Return Receipt (electronic)	\$0.00
<input type="checkbox"/> Certified Mail Restricted Delivery	\$0.00
<input type="checkbox"/> Adult Signature Required	\$0.00
<input type="checkbox"/> Adult Signature Restricted Delivery	\$0.00
Postage	\$1.20
Total Postage and Fees	\$7.60

LIHUE HI 96766
SEP 19 2020
Postmark Here
USPS

09/19/2020

Sent To	<u>Dept of water Mr. Greg Kamon</u>
Street and Apt. No., or PO Box No.	<u>Kurt Akamine 4399 Pua Loke</u>
City, State, ZIP+4®	<u>Lihue 96766</u>

PS Form 3800, April 2015 PSN 7530-02-000-9047 See Reverse for Instructions

7020 1290 0000 2546 2853

Total	
First-Class Mail® 1	\$1.20
Large Envelope	
Lihue HI 96766	
Weight: 0 Lb 1.50 Oz	
Estimated Delivery Date	
Tuesday 09/22/2020	
Certified Mail®	\$3.55
Tracking #:	
70201290000025462853	\$2.85
Return Receipt	
Tracking #:	
9590940256789346296540	\$7.60
Total	\$11.70

Grand Total:	\$11.70

Credit Card Remitted	\$11.70

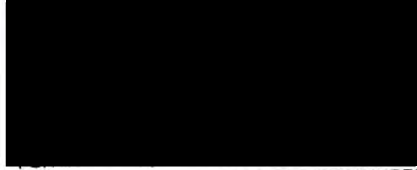

GEORGE MICHAEL BARKER

[REDACTED]
my water valve is at:
Gwen Sains property (east side)

[REDACTED]
Kupaa, KAUAI, HAWAII 96746

RETURN RECEIPT
REQUESTED

PLACE STICKER AT TOP OF ENVELOPE TO THE RIGHT
OF THE RETURN ADDRESS, FOLD AT DOTTED LINE

CERTIFIED MAIL



7020 1290 0000 2549 1273

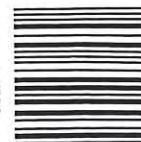

96766

U.S. POSTAGE PAID
FOM LG ENV
LHUE, HI
96766
SEP 29, 20
AMOUNT
\$0.25

R2304N117497-10



DEPARTMENT OF WATER - KAUAI
* Attention: VICE CHAIR JULIE SIMINTON
OR, Director/Asst. Director/Dept. of water
4398 PUA LOKE STREET
LHUE, KAUAI, HAWAII 96766

RECEIVED

RETURN RECEIPT
REQUESTED

Old Business

DEPARTMENT OF WATER

County of Kaua'i

"Water has no Substitute – Conserve It!"

MANAGER'S REPORT No. 19-47 (Update)

October 22, 2020

Re: Discussion and Possible Action for Board Approval to enter into the First Amendment to the Memorandum of Agreement between the Department of Public Works, County of Kaua'i and the Board of Water Supply, County of Kaua'i for the County's Kahilihoholo Road Culvert Repair Project and expenditure of funds in the amount of \$44,100.00

RECOMMENDATION:

It is recommended that the Board approve to enter into the First Amendment to the Memorandum of Agreement (MOA) with the Department of Public Works, County of Kaua'i for the County's Kahilihoholo Road Culvert Repair Project and approve the expenditure of funds in the amount of \$44,100.00.

FUNDING: Water Utility Fund –\$ 6,517,371 (estimated amount available pending year end closing adjustments)

Account No.	10-40-00-604-999		
Acct Description	WU/OPS/AdminCapital Outlay – Rehabilitation and Replacement		
Funds Available	Verified by WWC		
Contract No.	N/A		
Vendor	County of Kauai		
	Estimated Invoice Amount	\$	42,000.00
	5% Contingency	\$	2100.00
	Total Funds Certified To Date	\$	44,100.00

Contract NTP Date: N/A

Original Contract End Date: N/A

New Contract End Date if Contract Time Extension: N/A

BACKGROUND:

As a result of the historic flood of April 13-15, 2018, the Department of Public Works, County of Kaua'i (County) needed to reconstruct the portion of Kahilihoholo Road that was washed away. The washed out section of the roadway left the Department of Water's (DOW) water line exposed and unsupported. The County and the DOW decided that it would be advantageous for the County to repair the water line for the DOW with the County's road repair work. By comparison, the road would need to be repaired before the permanent water line could be repaired and replaced. Therefore, including the water line in the County's scope of work for the road repairs would allow for the permanent water line to be completed significantly sooner.

The County included the repair of the water line in their contract's scope of work for the road repairs. The understanding between the DOW and the County was that the DOW would reimburse the County for the

water line repair work done by the County, as it was in the best interest of the public to include the water main repairs with the road repairs.

A MOA between the County and the DOW was executed on April 26, 2019. In the terms of the MOA, the County would be requesting reimbursement (75% of the cost) from FEMA for the water line work completed by the County and the DOW would reimburse the County the remaining 25% or, amount not reimbursed to the County by FEMA.

Subsequent to the execution of the original MOA, the Hawai'i Emergency Management Agency (HIEMA) determined that although the County included the water line work in their scope of work for their contractor, the County's scope of work to FEMA did not include the water line work. HIEMA requested that the MOA completed be revised to specify that the DOW would be requesting reimbursement from FEMA for all of the water line work and the County shouldn't as it is not in the County's FEMA scope of work. HIEMA requested that the DOW submit a request to FEMA to consider that all of the water line work be considered for reimbursement. This was done. FEMA has not responded to our request yet so we do not know if we will be able to be reimbursed. In either case, the DOW will need to reimburse the County 100% of the cost of the water line work in good faith. The amended MOA would allow the DOW to reimburse the County.

Therefore, the Department is recommending that the Board approve the First Amendment to the MOA and the estimated funds to reimburse the County. The actual amount of the reimbursement will be known after the County submits the required invoices to the DOW.

OPTIONS:

Option 1: Approve the First Amendment to the Memorandum of Agreement and expenditure of \$44,100.00 in funds.

Pros: This will allow the Department of Water to reimburse the Department of Public Works (DPW), County of Kaua'i for 100% of the repairs for the affected water facilities due to the historic flood of April 13-15, 2018. Allowing DPW to be the lead agency for this work has saved the DOW time, manpower, resources, and money.

Cons: None.

Option 2: Do not Approve the First Amendment to the Memorandum of Agreement and expenditure of \$44,100.00 in funds.

Pros: None.

Cons: The DOW will not be able to reimburse the County for the emergency water line repair work the County completed for the DOW.

Not providing 100% of the total funding for the water line repair work could jeopardize the working relationship and corrode trust between the County and the DOW going forward. This could include any future emergency work which requires coordination between the County and DOW. In turn, this would be detrimental to the services we provide to the people of Kaua'i.

KA/ein

Attachments: First Amendment to the Memorandum of Agreement: Reconstruction of Kahilihoholo Road and Culvert Repairs, Kīlauea-Kalihiwai Water System

Mgrrp/October 2020/19-47/Discussion and Possible Action for Board Approval to enter into the First Amendment to the Memorandum of Agreement between the Department of Public Works, County of Kaua'i and the Board of Water Supply, County of Kaua'i for the County's Kahilihoholo Road Culvert Repair Project and expenditure of funds in the amount of \$44,100.00 (Update) (4-26-19, 10-22-20):ein

MEMORANDUM OF AGREEMENT

FOR

**KAHILIHOLE ROAD AND CULVERT REPAIRS
KĪLAUEA-KALIHIWAI WATER SYSTEM**

This FIRST AMENDMENT to the Memorandum of Agreement KAHILIHOLE ROAD AND CULVERT REPAIRS KILAUEA-KALIHIWAI WATER SYSTEM, dated April 26, 2019 (“Original Agreement”) effective as of _____, 2020 (“First Amendment,” collectively the “Agreement”), by and between the BOARD OF WATER SUPPLY, COUNTY OF KAUA`I (hereinafter referred to as the “BWS”), whose business and mailing address is 4398 Pua Loke Street, Līhu`e, Hawai`i 96766 and the COUNTY OF KAUA`I (hereinafter referred to as “COUNTY”) acting through its DEPARTMENT OF PUBLIC WORKS (hereinafter referred to as the “DPW”), whose principal place of business and mailing address is 4444 Rice Street, Suite 275, Līhu`e, Hawai`i 96766.

RECITALS

WHEREAS, the historic flood of April 13-15, 2018 damaged the County of Kaua`i’s Kahilihole Road including the water distribution system and its appurtenances along, under, and within Kahilihole Road; and

WHEREAS, the COUNTY is the owner of that certain parcel of land upon which Kahilihole Road is situated, including the County Right-of-Way; and

WHEREAS, the BWS is the owner of the water distribution system and appurtenances (herein referred to as “BWS Facilities”); and

WHEREAS, both the COUNTY, acting through its DPW, and BWS will seek funding reimbursement from the Federal Emergency Management Agency (“FEMA”) for costs related to the damage to Kahilihole Road; and

WHEREAS, the BWS desires to remove, repair, reconstruct and reinstall the BWS Facilities which are located within the Kahilihole Road and the County Right-of-Way; and

WHEREAS, the COUNTY is willing to include the removal, repair, reconstruction, and reinstallation of the BWS Facilities in the Kahilihole Road and Culvert Repair - Rain18 Project (the “Project”), provided that the BWS and the COUNTY, acting through the DPW, enter into the Original Agreement for the removal, repair, reconstruction, and reinstallation of the BWS Facilities; and

WHEREAS, the COUNTY will enter into a contract for the removal, repair, reconstruction, and reinstallation of the BWS Facilities as a portion of the overall Project; and

WHEREAS, FEMA and the Hawai'i Emergency Management Agency (HIEMA) have requested changes to provisions in the original MOA involving reimbursement of Project related costs; and

WHEREAS, the COUNTY included the removal, repair, reconstruction, and reinstallation of the BWS Facilities in the COUNTY's contract for the Project, which was submitted to FEMA.

WHEREAS, HI-EMA has determined that the BWS will need to request reimbursement from FEMA for the cost to remove, repair, reconstruct, and reinstall the BWS Facilities to be done under the COUNTY's contract for the Project, and that reimbursement from FEMA is anticipated to be 75% of the cost to remove, repair, reconstruct, and reinstall the BWS Facilities.

WHEREAS, The COUNTY shall not request reimbursement from FEMA for the cost to remove, repair, reconstruct, and reinstall the BWS Facilities as part of the COUNTY's Kahiliholo Road Project.

NOW THEREFORE, in consideration of the mutual covenants and promises herein made, the parties do hereby agree as follows:

1. This Agreement supersedes the original Memorandum of Agreement for Kahiliholo Road and Culvert Repairs Kilauea-Kalihiwai Water System that became effective on April 26, 2019.
2. The DPW shall utilize any and all BWS record drawings for the BWS Facilities available during the design of any road reconstruction of the County Roads. Specifically, DPW's Kahiliholo Road and Culvert Repair, Rain18 Project records.
3. The design of the BWS Facilities shall conform to Water System Standards, 2002, as amended, as reviewed and approved by BWS. The removal, repair, reconstruction, and reinstallation of the BWS Facilities shall be monitored and inspected by a BWS inspector. The BWS will issue a Final Inspection notice upon satisfactory completion of the removal, repair, reconstruction, and reinstallation of the BWS Facilities under the COUNTY's contract for the Project, and a Certification of Completion upon completion of the required post-construction submittals.
4. The COUNTY bid specifications and contract shall include:
 - a. The removal and proper disposal of the temporary water line and old/damaged BWS Facilities.
 - b. The repair, reconstruction, and reinstallation of the BWS Facilities.
5. The DPW shall provide copies of Project invoices which detail the completion of the removal, repair, reconstruction, and reinstallation of the BWS Facilities in a timely manner to allow the BWS adequate time to submit a request for reimbursement from FEMA.

6. The BWS shall pay the COUNTY for all of the Project costs attributable to the removal, repair, reconstruction, and reinstallation of the BWS Facilities within 60 days of receipt of the invoices outlined in item 5 above, or from the date of execution of this agreement, whichever is the later date.
7. This Agreement may be canceled by the mutual written agreement of the parties. This Agreement shall automatically terminate upon issuance of the Certificate of Completion for the BWS Facilities by the BWS except items 5 and 6 above which shall survive the termination of this Agreement.

[SIGNATURES OF THE NEXT PAGE]
[THE REMAINDER OF THIS PAGE IS INTENTIONAL LEFT BLANK]

IN WITNESS WHEREOF, the undersigned have executed this Agreement the day and year first above written.

RECOMMEND APPROVAL:

BOARD OF WATER SUPPLY
COUNTY OF KAUA'I

Department of Water

Kurt Akamine
Chairperson
Board of Water Supply

APPROVED AS TO FORM
AND LEGALITY:

Mahealani M. Krafft
Deputy County Attorney

RECOMMEND APPROVAL:

APPROVED:

Troy Tanigawa
Acting County Engineer
County of Kaua'i

Reiko Matsuyama
Director of Finance
County of Kaua'i

APPROVED AS TO FORM
AND LEGALITY:

Mark L. Ishmael
Deputy County Attorney

DEPARTMENT OF WATER

County of Kaua'i

"Water has no Substitute – Conserve It!"

MANAGER'S REPORT No. 20-41 (Update)

October 22, 2020

Re: Waiahi Surface Water Treatment Plant Renovation Construction Cost Progress Report

RECOMMENDATION:

There is no action necessary; for Board review and discussion purposes only.

FUNDING: N/A.

BACKGROUND:

As requested by the Board of Water during its January 24th and February 28th Regular Board meeting, the Board requested the Department to provide a monthly update on the status of payments to Grove Farm in accordance with the project's budget. Please refer to Attachment 1.

There are no updates to report since the August 27, 2020 Board meeting.

BW/ein

Attachment(s): Waiahi Surface Water Treatment Plant Renovation Construction Cost Progress Report as of September 15, 2020

Mgrpp/September 2020/20-41/Waiahi Surface Water Treatment Plant Renovation Project Construction Cost Progress Report (Update) (1-24-20, 2-28-20, 6-25-20, 7-23-20, 8-27-20, 9-24-20, 10-22-20):ein

**Waiahi SWTP Renovation
Maintaining 3.0 MGD
Construction Costs**

Item No.	Qty.	Unit	Cost Per Unit	Description	Total Cost Estimate	Grove Farm Total (1/3) 33.33%	BWS Total (2/3) 66.67%	BWS Total Amount Due to Date (\$)	BWS Amount Paid to Date (\$)	Estimate Total to Date (% Line Item)	All Payments Received by Grove Farm within 15 days?
SITEWORK¹											
1	1	LS	\$100,000	Mobilization & Demobilization	\$100,000	\$33,333	\$66,667	\$0	\$0	0.00%	N/A
2	1.44	Acre	\$14,876	Clearing & Grubbing, including demolition of existing shed at Off-site Detention Basins, in place complete	\$21,421	\$7,140	\$14,281	\$0	\$0	0.00%	N/A
3	4151	CY	\$30	Excavation, in place complete	\$124,530	\$41,510	\$83,020	\$0	\$0	0.00%	N/A
4	2673	CY	\$15	Embankment, in place complete.	\$40,095	\$13,365	\$26,730	\$0	\$0	0.00%	N/A
5	1	LS	\$11,950	Erosion Control, including temp silt fence, temp wheel wash area, temp ground cover & erosion control fabric	\$11,950	\$3,983	\$7,966	\$0	\$0	0.00%	N/A
6	16	SY	\$450	Rip-rap Lined Embankment Swale, in place complete	\$7,200	\$2,400	\$4,800	\$0	\$0	0.00%	N/A
7	956	LF	\$80	Chain Link Fence, including warning signs, in place complete	\$76,480	\$25,493	\$50,987	\$0	\$0	0.00%	N/A
8	1	EA	\$2,500	Chain Link Gate, 18' Wide X 6' High at Off-site Detention Basins, in place complete.	\$2,500	\$833	\$1,667	\$0	\$0	0.00%	N/A
9	1	EA	\$1,000	Chain Link Pedestrian Gate, 30" Wide X 6' High at Drain/Reject Water Pump Station, in place complete	\$1,000	\$333	\$667	\$0	\$0	0.00%	N/A
10	2434	SY	\$80	Asphalt Concrete Pavement, including base course, in place complete	\$194,720	\$64,907	\$129,813	\$0	\$0	0.00%	N/A
11	1055	LF	\$55	Concrete curb, in place complete	\$58,025	\$19,342	\$38,683	\$0	\$0	0.00%	N/A
12	1321	LF	\$45	Concrete header, in place complete	\$59,445	\$19,815	\$39,630	\$0	\$0	0.00%	N/A
13	8	EA	\$250	Concrete drop curb, in place complete	\$2,000	\$667	\$1,333	\$0	\$0	0.00%	N/A
14	13	EA	\$800	Bollards, in place complete.	\$10,400	\$3,467	\$6,933	\$0	\$0	0.00%	N/A
15	2	EA	\$500	Ring Buoy, including pipe stand, in place complete	\$1,000	\$333	\$667	\$0	\$0	0.00%	N/A
YARD PIPING¹											
1	1	LS	\$58,000	Pre-lube Line for Existing Reservoir Intake Pumps, including fittings and appurtenances, in place complete	\$58,000	\$19,333	\$38,667	\$0	\$0	0.00%	N/A
2	1	LS	\$123,000	Flocculation Tank Inlet Line, including fittings, valves, and appurtenances, cutting, removing and relocating	\$123,000	\$41,000	\$82,000	\$0	\$0	0.00%	N/A

**Waiahi SWTP Renovation
Maintaining 3.0 MGD
Construction Costs**

Item No.	Qty.	Unit	Cost Per Unit	Description	Total Cost Estimate	Grove Farm Total (1/3) 33.33%	BWS Total (2/3) 66.67%	BWS Total Amount Due to Date (\$)	BWS Amount Paid to Date (\$)	Estimate Total to Date (% Line Item)	All Payments Received by Grove Farm within 15 days?
3	1	LS	\$29,000	Drainline "A", including connection to existing drain manholes & modifications to existing DMH "A-2"	\$29,000	\$9,667	\$19,333	\$0	\$0	0.00%	N/A
4	1	LS	\$150,000	Drainline "B," including headwall with ungrouted rip rap, & drain manholes, in place complete	\$150,000	\$50,000	\$100,000	\$0	\$0	0.00%	N/A
5	1	LS	\$24,000	Drainline "C", including headwalls, in place complete	\$24,000	\$8,000	\$16,000	\$0	\$0	0.00%	N/A
6	1	LS	\$130,000	Force Mains "A", "B" & "C", including fittings, valves & appurtenances, & concrete blocks	\$130,000	\$43,333	\$86,667	\$0	\$0	0.00%	N/A
7	1	LS	\$69,182	Off-Site Detention Basin Inlet & Outlet Lines, including residuals discharge connection	\$69,182	\$23,061	\$46,121	\$0	\$0	0.00%	N/A
8	1	LS	\$28,302	Residuals Discharge Lines "A" & "B", including fittings, valves & appurtenances & concrete blocks	\$28,302	\$9,434	\$18,868	\$0	\$0	0.00%	N/A
9	1	LS	\$75,472	Residuals Drying Beds Inlet Lines, including fittings, valves & appurtenances, concrete blocks	\$75,472	\$25,157	\$50,315	\$0	\$0	0.00%	N/A
STRAINER SYSTEM¹											
1	1	LS	\$120,000	16" Automatic Backwashing Strainer, including removal & disposal of ex. strainer, drain & backwash lines	\$120,000	\$40,000	\$80,000	\$0	\$0	0.00%	N/A
PUMP GALLERY IMPROVEMENTS¹											
1	1	LS	\$5,000	Liquid Level Sensor Alarm System, in place complete	\$5,000	\$1,667	\$3,333	\$0	\$0	0.00%	N/A
2	1	LS	\$5,000	8" Butterfly Valve on Permeate Line to Backpulse Tank, in place complete	\$5,000	\$1,667	\$3,333	\$0	\$0	0.00%	N/A
3	1	LS	\$10,000	Replace Existing Membrane Tank Level Transmitters. (Transmitters furnished by SUEZ. See Bid Item G-1.)	\$10,000	\$3,333	\$6,667	\$0	\$0	0.00%	N/A
4	1	LS	\$10,000	Combined Permeate Turbidimeter, including sampling line & revisions to sample drains & control wiring	\$10,000	\$3,333	\$6,667	\$0	\$0	0.00%	N/A
DRAIN/REJECT WATER PUMP STATION¹											
1	1	LS	\$44,025	Drain/Reject Water Pump Station Concrete Wet Well & Pipe Support, including structural excavation	\$44,025	\$14,675	\$29,350	\$0	\$0	0.00%	N/A

**Waiahi SWTP Renovation
Maintaining 3.0 MGD
Construction Costs**

Item No.	Qty.	Unit	Cost Per Unit	Description	Total Cost Estimate	Grove Farm Total (1/3) 33.33%	BWS Total (2/3) 66.67%	BWS Total Amount Due to Date (\$)	BWS Amount Paid to Date (\$)	Estimate Total to Date (% Line Item)	All Payments Received by Grove Farm within 15 days?
2	1	LS	\$69,182	Drain/Reject Water Pump System, including liquid level sensor, transducer, pump accessories, access hatch	\$69,182	\$23,061	\$46,121	\$0	\$0	0.00%	N/A
3	1	LS	\$62,893	Drain/Reject Water Piping, including fittings, valves & appurtenances, & connection to existing drain line	\$62,893	\$20,964	\$41,929	\$0	\$0	0.00%	N/A
MEMBRANE UNIT REPLACEMENT²											
1	1	LS	\$1,015,545	Membrane Unit Upgrades by SUEZ, all in accordance with SUEZ's proposal dated 9/6/2019.	\$1,015,545	\$338,515.00	\$677,030	\$677,030.00	\$677,030.00	100.00%	Yes
2	1	LS	\$160,941	Installation of Membrane Unit Upgrades by SUEZ, in place complete. Aqua Engineers, proposal dated 9/16/2019	\$160,941	\$53,647.00	\$107,294	\$107,294.00	\$107,294.00	100.00%	Yes
3	1	LS	*Initial estimate \$0	Taxes & Additional US Customs Duty Fees, in accordance with SUEZ's proposal (*estimate was \$0)	\$47,852.48	\$15,950.83	\$31,901.65	\$31,901.65	\$31,901.65	100.00%	Yes
LINER FOR OFF-SITE DETENTION BASINS¹											
1	1	LS	\$119,497	Liner for Off-Site Detention Basins, including geotextile fabric, anchoring battens & trenches	\$119,497	\$39,832	\$79,665	\$0	\$0	0.00%	N/A
PORTABLE PUMP FOR RESIDUALS TRANSFER³											
1	1	LS	\$41,024	Portable Pump for Residuals Transfer, including wheel kit & hoses, in place complete.	\$41,024	\$13,675	\$27,349	\$0	\$0	0.00%	N/A
GENERATOR BUILDING¹											
1	1	LS	\$350,000	Generator Building	\$350,000	\$116,667	\$233,333	\$0	\$0	0.00%	N/A
2	1	LS	\$300,000	Emergency Generator System	\$300,000	\$100,000	\$200,000	\$0	\$0	0.00%	N/A
3	1	LS	\$28,000	Painting and Coating	\$28,000	\$9,333	\$18,667	\$0	\$0	0.00%	N/A
ELECTRICAL WORK¹											
1	1	LS	\$493,192	Electrical Work, in place complete.	\$493,192	\$164,397	\$328,795	\$0	\$0	0.00%	N/A

**Waiahi SWTP Renovation
Maintaining 3.0 MGD
Construction Costs**

Item No.	Qty.	Unit	Cost Per Unit	Description	Total Cost Estimate	Grove Farm Total (1/3) 33.33%	BWS Total (2/3) 66.67%	BWS Total Amount Due to Date (\$)	BWS Amount Paid to Date (\$)	Estimate Total to Date (% Line Item)	All Payments Received by Grove Farm within 15 days?
----------	------	------	---------------	-------------	---------------------	----------------------------------	---------------------------	-----------------------------------	------------------------------	--------------------------------------	---

Summary for October 22, 2020 Board Meeting

	Total Cost Estimate	GF Total 1/3 (33.33%)	BWS Total 2/3 (66.67%)	BWS Total Amount Due to Date (\$)	BWS Total Amount Paid to Date (\$)	Estimate Total to Date (% of total project)	All Payments Received by Grove Farm within 15 days?
Project Total Estimates =	\$4,279,874	\$1,426,625	\$2,853,249	\$816,226	\$816,226	28.61%	Yes

DOW NOTES

*Payments due within 15 calendar days of receipt of invoice.

*DOW will not be withholding 5% retainage.

New Business

DEPARTMENT OF WATER

County of Kaua'i

"Water has no Substitute – Conserve It!"

MANAGER'S REPORT No. 21-12

October 22, 2020

Re: Discussion and Possible Action on the Fourth Amendment to Contract No. 639 Job No. 17-10, WP2020 Project No. KW-07 Rehabilitate Paua Valley Tank #1, 0.5MG Concrete, with KAI Hawaii Inc. for a time extension of 150 days and for additional design funding in the amount of \$212,719.00

RECOMMENDATION:

It is recommended that the Board approve a second amendment to Contract No. 639 with KAI Hawaii Inc. for the subject project for a time extension of 150 days and additional design funding in the amount of \$212,719.00.

FUNDING:

Account No.	10-20-00-604-000			
Acct Description	WU/Eng/AdminCapitalOutlay-Rehabilitation and Replacement			
Funds Available	Water Utility Fund -Unrestricted			\$ Fiscal to provide
Contract No.	639			
Vendor	KAI Hawaii, Inc.			
	Contract Amount	\$	93,625.52	
	Amendment 1 Additional Amount	\$	68,795.00	
	Amendment 2 Additional Amount	\$	11,636.00	
	Amendment 3 Amount (Credit)	\$	-2.12	
	Total Funds Certified To Date	\$	174,054.40	
Amendment:				
	Additional Funds Requested for Amendment 4:	\$	212,719.00	
	Proposed New Contract Amount	\$	386,773.40	
	Fund Balance			\$ Fiscal to provide

BACKGROUND:

Contract NTP Date: July 10, 2017
 Original Contract End Date: March 16, 2018
 New Contract End Date: Estimate March 21, 2021

The DOW started Job No. 17-10, WP2020 Project No. KW-07 Rehabilitate Paua Valley Tank #1, 0.5MG Concrete to address the aging tank located in Kekaha and to perform repairs,

including fixing a leak located at the base of the tank. As part of the project, DOW performed hazardous material surveys to ensure proper disposal of any material intended to be removed. The presence of polychlorinated biphenyls (PCBs) within the interior of the tank was not expected, based on DOW prior tests for PCBs of the tank water. However, results of the hazardous material survey identified the presence of polychlorinated biphenyls (PCBs) within the interior liner of the tank (testing for PCBs on exterior of tank was not required), which required the shutdown of the tank and the involvement of the Department of Health (DOH) Hazard Evaluation and Emergency Response Office (HEER) and the Environmental Protection Agency (EPA) to provide direction of proper removal and disposal of the PCBs. Design mitigation of PCBs if detected was not included in the scope of work.

First Amendment (executed May 15, 2018)

After discussions with HEER and EPA, specifications needed to be provided for proper removal and disposal of the interior liner of the tank. Additionally, the soils in the drainage ditch needed to be tested for the presences of PCBs, as this is where the tank discharges overflow or washout water.

Second Amendment (executed September 11, 2019):

Testing from the drainage ditch resulted in the presence of PCBs within the soils. Requirements from EPA require that a PCB soil removal plan must be developed and approved by the EPA and HEER for proper mitigation of the soil in the ditch. Therefore, the second contract amendment was necessary to complete the PCB soil removal plan to satisfy requirements from HEER and EPA. EPA clarified that construction of the tank rehabilitation was not dependent on the soil removal plan and mitigation of the soil in the ditch and could proceed independently from the soil mitigation of the ditch. The DOW decided to proceed with the construction of the tank rehabilitation.

Third Amendment (executed June 8, 2020):

During the initial stages of construction, the Construction Contractor submitted an RFI requesting that the exterior paint be tested for PCB contamination on the basis that two other DOW tanks have recently tested positive for PCBs in the exterior paint. PCB sampling in the exterior paint is not typically required by the Department of Health or EPA, but the DOW voluntarily chose to sample the exterior coatings of the Pa'anau Tank No. 1 and Kaua'i Inn Tanks as part of Job No. 18-02, the Island-Wide Tank Rehabilitation of Tanks Project. The positive results from those two tanks led the Construction Contractor to request that the Paua Valley Tank project be tested on the basis that they were built during the same timeframe and may have used similar materials.

DOW staff met with EPA Region IX to request a determination as to whether PCB testing of the exterior paint was required. The EPA representative stated that PCB testing is not a standalone requirement; however, it was clarified by EPA that based on case law in California, the EPA can now "reasonably require" the DOW to test the exterior paint for PCBs at the Paua Valley tank because two other tanks in the DOW system tested positive. Therefore, the DOW proceeded with testing the tank's exterior paint for PCBs. Should the results indicate that PCBs are present, additional mitigation will be needed for the removal and disposal of the paint and the Construction Contractor will submit a change order for the project.

Fourth Amendment (proposed):

The PCB sampling results for the exterior paint and roof coating on the Paua Valley Tank (Reservoir No. 1) were positive for PCB. As a result of this, EPA is requiring testing of the soil

and asphalt paving surrounding the reservoir. Additional environmental and engineering work are required to comply with EPA and DOH requirements. Depending on the test results further testing and mitigation may be required. We have reviewed the proposal from KAI Hawaii, Inc. for additional services required and find it acceptable.

Summary of Design:

- **July 10, 2017** - Original contract NTP – Consultant completed hazardous material testing required in the contract scope of work. Consultant test results report in December 2017 included detection of PCBs in the interior lining of the tank. DOW did not expect this. (note: testing of the tank exterior for PCBs was not required by DOH or EPA at that time and not included in the design scope of work)
- **May 15, 2018** – 1st Amendment to contract executed. Amendment is to address EPA requirement for DOW to mitigate/dispose of interior tank lining and to test soil in drainage ditch (off-site from tank site) for PCBs.
- **September 11, 2019** – 2nd Amendment to contract executed. Amendment is to address PCBs being detected in the soil samples from the drainage ditch and subsequent EPA and DOH HEER requirements to address the PCB detected in the ditch soil. EPA clarified that construction of the Paua Tank can proceed, as it is not contingent on the mitigation of the PCB detected in the drainage ditch soil. DOW decided to proceed with construction and a construction contract was executed.
- **June 8, 2020** – 3rd Amendment to contract executed. Amendment is to address Construction Contractor's request to test exterior of tank for PCBs and subsequent EPA determination that the testing of the tank exterior needed to be done. This Amendment is for the consultant to complete the additional testing required by EPA.
- **October 22, 2020** – Proposed 4th Amendment to contract. Amendment is to address PCBs being detected in the exterior paint and roofing material of the tank and subsequent EPA requirement to test the asphalt paving and soil surrounding the tank for PCBs.

OPTIONS:

Option 1: Approve \$212,719.00 in additional funds for the subject contract.

Pro: This will allow DOW to adhere to requirements from HEER and EPA to develop an approved plan and test for PCB contaminated asphalt/soils around the Paua Valley 0.5 MG tank.

Con: Additional funds will be expended.

Option 2: Do not approve \$212,719.00 in additional funds for the subject contract.

Pro: Additional funds will not be expended.

Con: The DOW will not be able to adhere to the requirements from HEER and EPA to develop an approved plan and test for PCB contaminated asphalt/soils around the tank site. The project cannot be completed.

KA/ein

Mgrrp/October 2020/21-12/Discussion and Possible Action on the Fourth Amendment to Contract No. 639 Job No. 17-10, WP2020 Project No. KW-07 Rehabilitate Paua Valley Tank #1, 0.5MG Concrete, with KAI Hawaii Inc. for a time extension of 150 days and for additional design funding in the amount of \$212,719.00 (10-22-20):ein

Staff Reports



DEPARTMENT OF WATER

County of Kaua'i

"Water has no Substitute – Conserve It!"

FISCAL REPORT: MONTHLY SUMMARY HIGHLIGHTS – SEPTEMBER, 2020

I. BUDGET SUMMARY VS. ACTUAL (see attached report for details)

YEAR TO DATE (YTD) BUDGET & ACTUAL EXPENSES SUMMARY – AS OF SEPTEMBER, 2020

	<u>BUDGET</u>	<u>vs</u>	<u>EXPENSED</u>
· Operating Expenses	\$11,486,410		\$5,969,158
· Debt Principal Payment	4,014,034		4,014,034
· Capital Projects	<u>23,736,222</u>		<u>279,605</u>
TOTAL	<u>\$39,236,666</u>		<u>\$10,262,797</u>

REVENUES: VARIANCE = "ACTUAL" LESS "BUDGET"; POSITIVE INDICATES HIGHER PERFORMANCE THAN EXPECTED.

- Total Revenue as of September 2020 was 3% below projection.
 - Water sales of \$6.8 million (M) was \$1.1M higher than projected.
 - Other Water Revenue - Receipts of \$49 thousand (K) was \$26K below projection or – (35%).
 - Capital Contributions: Contributions from Federal & State Grants – \$200.3K from BAB Subsidy.
 - Investment Income & Net Increase in FV of Investments –\$127.4K.
 - Miscellaneous Revenues - None

OPERATING EXPENSES: VARIANCE = BUDGET LESS ACTUAL

EXPENSES; POSITIVE INDICATES LESS SPENDING THAN PLANNED. **REVISED YTD BUDGET COLUMNS INCLUDE PO ROLLOVER FROM FY ENDING 2020.**

- YTD Operating Expenses before depreciation and amortization was \$6M. Total spending was \$5.5M less than planned or budgeted based on the revised budget that included the FY 2020 PO rollovers; a positive variance of 48%.
 - Employee Related Expenses –\$3M with a 6% negative variance.
 - Contracts & Services – \$1.2M with an 80% positive variance.
 - Professional Services, Other Services – Billing, Communication, Insurance and Repairs and Maintenance for non-water systems are the main items contributing to the 80% positive variance.
 - Exceptional Expenses – None.
 - Fuel & Utilities – \$650.3K with a 19% positive variance.
 - Bulk Water Purchase –\$188.6K with a 59% positive variance.
 - Office & Operating Supplies – \$212K with 65% positive variance.
 - Training, Travel & Meeting Expenses – \$4.7K.
 - Debt Service – Interest Expense - \$735.9 with 3% positive variance.
 - Depreciation & Amortization (non-cash expenses) is \$1.8M with 1% negative variance.



DEPARTMENT OF WATER

County of Kaua'i

"Water has no Substitute – Conserve It!"

NET OPERATING INCOME:

- Net Operating Income before depreciation and amortization - \$1.77M
- Net Operating Income (loss) after depreciation & amortization was a negative \$26.6K.

NON-OPERATING PROCEEDS & DISBURSEMENTS

- SRF Loan Proceeds – None.
- FRC – Facility Reserve Charge –\$571.8K.
- YTD Debt Principal Payment is \$4M.

CAPITAL PROJECTS BUDGET: YTD DISBURSEMENTS = \$279,605.32

- Capital Projects: Water Utility Fund - \$236.4K
- Capital Projects: FRC Fund – None
- Capital Projects: BAB Fund - \$43.3K
- Capital Projects: SRF Loan Fund - None

II. FY 2020 – 2021 CERTIFICATION OF FUNDS YTD \$691,831.62.

	REPORT TO MANAGER (with approved Budget)	MANAGER'S REPORT (New Budget Requests)
Water Utility Fund	\$331,814.62	\$360,017.00
FRC Fund	\$.00	\$.00
BAB Fund	\$.00	\$.00
Total	\$331,814.62	\$360,017.00

III. COMPARATIVE CHARTS:

METERED CONSUMPTION:

- September 2020 monthly-metered consumption was 329.9 million gallons (mg) which decreased by 39.9 mg or 11% as compared from the same month of FY 2020.
- Year to Date (YTD) metered consumption as of 9/30/20 was 960.4 mg with a YTD cumulative decrease of 137.3 mg or 13% as compared from the same month of FY 2020.

IV. COMPARATIVE BALANCE SHEET: SEE ATTACHED.

Statement of Net Position as of September 30, 2020 – Not available.

V. OTHER FISCAL ONGOING ACTIVITIES/INITIATIVES:

- The County of Kaua'i's HGEA and EM employees including DOW's HGEA and EM employees received their new increased salary rates as of July 1, 2020 on October 15, 2020. Retroactive payments for all differentials will be paid on October 31, 2020. Funding were included in the DOW's approved budgets for FY 2020 and 2021 so no separate board approval is required for DOW.
- FY 2020 Financial Audit is still in progress.
- Ongoing; Water Audit for Calendar Year 2020.



DEPARTMENT OF WATER

County of Kaua'i

"Water has no Substitute – Conserve It!"

- Develop Financial Policies for DOW – Statement of Qualifications were solicited for FY 2021, DOW will proceed with procurement.
- Budget Program Solution – It will be addressed concurrently with the Financial Policies Development procurement.
- Five (5) years Water Rate Study terminated; DOW will restart with an updated consumer database. Foresee procurement beginning of FY 2022.
- FEMA update: DOW submitted a request for an additional 30 months' extension to complete two outstanding projects for FEMA grant funding reimbursement; the Makaleha tunnel and Mānoa Stream.
- On-going; Fiscal and IT are working together to implement Office 365; Great Plains (GP) upgrade to the cloud, update the 2007 Depreciation Study & implement Share point in the cloud.
- Depreciation Study – Kicked off meeting with Consultants was completed. Anticipated completion is 11/2020.

MY/ein



Department of Water, County of Kauai
 Monthly Budget Summary vs. Actual
 SUMMARY
 9/30/2020

	September				FY 2021			
	Original Budget	Revised Budget	Actual	Variance	Revised YTD Budget	YTD Actual	*Variance	Variance %
I. OPERATING BUDGET								
Revenue								
Water Sales	\$1,916,124.00	\$1,916,124.00	\$2,311,942.18	\$395,818.18	\$5,748,372.00	\$6,819,561.40	\$1,071,189.40	19%
Revenue from Public Fire Protection	181,192.00	181,192.00	181,191.50	(0.50)	543,576.00	543,574.50	(1.50)	
Other Water Revenue	25,000.00	25,000.00	31,880.52	6,880.52	75,000.00	49,023.83	(25,976.17)	(35%)
Federal Grants	89,069.00	89,069.00		(89,069.00)	267,207.00		(267,207.00)	(100%)
State Grants	375,000.00	375,000.00		(375,000.00)	1,125,000.00		(1,125,000.00)	(100%)
Capital Contributions	46,723.00	46,723.00	66,761.61	20,038.61	140,169.00	200,284.83	60,115.83	43%
Net Increase in Fair Value of Investments	2,500.00	2,500.00	(10,829.96)	(13,329.96)	7,500.00	(31,082.43)	(38,582.43)	(514%)
Investment Income	11,250.00	11,250.00	63,577.81	52,327.81	33,750.00	158,454.46	124,704.46	369%
Gain or Loss on Disposal of Capital Assets	417.00	417.00		(417.00)	1,251.00		(1,251.00)	(100%)
Gain or Loss from the Retirement of Debt								
Miscellaneous Revenues	83.00	83.00	(15.58)	(98.58)	249.00	(72.86)	(321.86)	(129%)
Total Revenue	2,647,358.00	2,647,358.00	2,644,508.08	(2,849.92)	7,942,074.00	7,739,743.73	(202,330.27)	(3%)
Employee-Related Expenses								
Salaries and Wages (includes Leaves & CTO)	541,224.00	541,224.00	453,506.98	87,717.02	1,623,672.00	1,593,463.85	30,208.15	2%
Temporary Assignment	5,042.00	5,042.00	6,422.59	(1,380.59)	15,126.00	27,753.78	(12,627.78)	(83%)
Overtime	39,750.00	39,750.00	55,922.78	(16,172.78)	119,250.00	204,810.95	(85,560.95)	(72%)
Standby	16,250.00	16,250.00	18,499.11	(2,249.11)	48,750.00	62,886.71	(14,136.71)	(29%)
FICA	46,075.00	46,075.00	38,825.96	7,249.04	138,225.00	136,589.81	1,635.19	1%
Retirement Contribution	143,644.00	143,644.00	120,634.32	23,009.68	430,932.00	421,166.05	9,765.95	2%
Life & Health Insurance	53,623.00	53,623.00	47,347.00	6,276.00	160,869.00	163,209.88	(2,340.88)	(1%)
Workers Compensation								
Unemployment Compensation								
Post Employment Benefits (OPEB)	89,748.00	89,748.00	106,679.32	(16,931.32)	269,244.00	374,293.10	(105,049.10)	(39%)
Total Employee-Related Expenses	935,356.00	935,356.00	847,838.06	87,517.94	2,806,068.00	2,984,174.13	(178,106.13)	(6%)
Contracts & Services								
Professional Services-General	294,316.00	294,316.00	150,742.47	143,573.53	4,499,525.78	342,015.04	4,157,510.74	92%
Professional Services-Accounting & Auditing	8,900.00	8,900.00	35,000.00	(26,100.00)	137,300.00	45,000.00	92,300.00	67%
Other Services-General	4,249.00	4,249.00	5,123.97	(874.97)	57,267.50	13,098.08	44,169.42	77%
Other Services-Billing Costs	14,952.00	14,952.00	20,781.21	(5,829.21)	132,363.83	32,754.72	99,609.11	75%
Public Relations-General	9,644.00				16,911.67	3,854.83	13,056.84	77%
Procurement Advertising	833.00	833.00		833.00	22,499.00	12,090.01	10,408.99	46%
Communication Services	10,871.00	10,871.00	15,817.14	(4,946.14)	83,641.45	29,455.36	54,186.09	65%
Freight and Postage	1,198.00	1,198.00	1,067.95	130.05	4,660.78	1,122.76	3,538.02	76%
Rentals and Leases	10,923.00	10,923.00	3,316.83	7,606.17	51,728.96	21,459.37	30,269.59	59%
Insurance	12,917.00	12,917.00		12,917.00	38,751.00		38,751.00	100%
County Service Charge	181,192.00	181,192.00	181,191.50	0.50	543,576.00	543,574.50	1.50	
Repairs and Maintenance-Water System	17,583.00	17,583.00	6,510.01	11,072.99	58,717.02	6,510.01	52,207.01	89%
Repairs and Maint-Non Water System	30,391.00	30,391.00	35,819.52	(5,428.52)	367,348.47	142,464.77	224,883.70	61%
Total Contracts & Services	597,969.00	588,325.00	455,370.60	132,954.40	6,014,291.46	1,193,399.45	4,820,892.01	80%



Department of Water, County of Kauai
 Monthly Budget Summary vs. Actual
 SUMMARY
 9/30/2020

	September				FY 2021			
	Original Budget	Revised Budget	Actual	Variance	Revised YTD Budget	YTD Actual	*Variance	Variance %
Exceptional Expenses								
FY2014 & FY2015 Kalaheo Emergency								
FY 2015 Kilauea								
Abandoning Hanamaulu Wells 1 & 2								
Total Exceptional Expenses								
Fuel & Utilities								
Utility Services	238,657.00	238,657.00	232,128.52	6,528.48	754,452.30	629,596.23	124,856.07	17%
Fuel	10,208.00	10,208.00	6,328.45	3,879.55	48,106.50	20,720.51	27,385.99	57%
Total Fuel & Utilities	248,865.00	248,865.00	238,456.97	10,408.03	802,558.80	650,316.74	152,242.06	19%
Bulk Water Purchase								
Bulk Water Purchase	151,681.00	151,681.00	43.03	151,637.97	455,043.00	188,640.73	266,402.27	59%
Total Bulk Water Purchase	151,681.00	151,681.00	43.03	151,637.97	455,043.00	188,640.73	266,402.27	59%
Office & Operating Supplies								
Office Supplies	1,833.00	1,833.00	1,865.98	(32.98)	5,850.26	5,784.26	66.00	1%
Operating Supplies	78,484.00	78,484.00	79,361.09	(877.09)	575,146.59	205,252.76	369,893.83	64%
Books, Subscriptions and Dues	5,874.00	5,874.00	1,004.00	4,870.00	31,072.00	1,004.00	30,068.00	97%
Books, Subscriptions and Dues - Board	91.00	91.00	91.00	91.00	273.00	273.00	273.00	100%
Total Office & Operating Supplies	86,282.00	86,282.00	82,231.07	4,050.93	612,341.85	212,041.02	400,300.83	65%
Training, Travel & Meeting Expenses								
Training and Development	6,966.00	6,966.00	2,188.51	4,777.49	20,898.00	4,705.28	16,192.72	77%
Travel and Per Diem	4,638.00	4,638.00	4,638.00	4,638.00	13,914.00	13,914.00	13,914.00	100%
Travel and Per Diem - Board								
Meeting Expense	1,656.00	1,656.00	1,656.00	1,656.00	4,968.00	4,968.00	4,968.00	100%
Meeting Expense - Board								
Total Training, Travel & Meeting Expenses	13,260.00	13,260.00	2,188.51	11,071.49	39,780.00	4,705.28	35,074.72	88%
Debt Service								
Interest Expense	252,109.00	252,109.00	245,293.44	6,815.56	756,327.00	735,880.32	20,446.68	3%
Total Interest Expense	252,109.00	252,109.00	245,293.44	6,815.56	756,327.00	735,880.32	20,446.68	3%
Total Operating Expenses	2,285,522.00	2,275,878.00	1,871,421.68	404,456.32	11,486,410.11	5,969,157.67	5,517,252.44	48%
Net Operating Income (Loss) Before Depreciation & Amortization	\$361,836.00	\$371,480.00	\$773,086.40	\$401,606.40	(\$3,544,336.11)	\$1,770,586.06	\$5,314,922.17	(150%)
Depreciation & Amortization								
Depreciation	541,667.00	541,667.00	496,056.65	45,610.35	1,625,001.00	1,738,471.21	(113,470.21)	(7%)
Amortization	62,721.00	62,721.00	62,721.00	62,721.00	188,163.00	58,733.31	129,429.69	69%
Total Depreciation & Amortization	604,388.00	604,388.00	496,056.65	108,331.35	1,813,164.00	1,797,204.52	15,959.48	1%
Net Operating Income (Loss)	(242,552.00)	(232,908.00)	277,029.75	509,937.75	(5,357,500.11)	(26,618.46)	5,330,881.65	(100%)



Department of Water, County of Kauai
 Monthly Budget Summary vs. Actual
 SUMMARY
 9/30/2020

	September				FY 2021			
	Original Budget	Revised Budget	Actual	Variance	Revised YTD Budget	YTD Actual	*Variance	Variance %
Non Operating Proceeds								
FRC-Facility Reserve Charge	33,333.00	33,333.00	185,523.55	152,190.55	99,999.00	571,778.55	471,779.55	472%
Total Non Operating Proceeds	33,333.00	33,333.00	185,523.55	152,190.55	99,999.00	571,778.55	471,779.55	472%
Transfers Out(In) to Other Funds								
Debt Principal Payment	430,045.00	3,153,944.00		3,153,944.00	4,014,034.00	4,014,034.21	(0.21)	
Net Proceeds (Expenditures)	(639,264.00)	(3,353,519.00)	462,553.30	3,816,072.30	(9,271,535.11)	(3,468,874.12)	5,802,660.99	(63%)
II. CAPITAL BUDGET								
Capital Projects (See Attached for Details)	2,350,620.00	2,350,620.00	78,365.89	2,272,254.11	23,736,221.81	279,605.32	23,456,616.49	99%



Department of Water, County of Kauai
 Monthly Budget Summary vs. Actual
 SUMMARY
 9/30/2020

	September				FY 2021			
	<u>Original Budget</u>	<u>Revised Budget</u>	<u>Actual</u>	<u>Variance</u>	<u>Revised YTD Budget</u>	<u>YTD Actual</u>	<u>*Variance</u>	<u>Variance %</u>
Capital Projects (See Attached for Details):								
Water Utility - Capital Projects (See Attached for Details)	1,794,370.00	1,794,370.00	76,865.89	1,717,504.11	18,621,274.87	236,355.32	18,384,919.55	99%
FRC Special Trust Fund - Capital Projects (See Attached for Details)	56,250.00	56,250.00		56,250.00	639,633.22		639,633.22	100%
BAB Fund - Capital Projects (See Attached for Details)	500,000.00	500,000.00	1,500.00	498,500.00	4,475,313.72	43,250.00	4,432,063.72	99%
SRF Loan Fund - Capital Projects (See Attached for Details)								
Total Capital Projects (See Attached for Details)	2,350,620.00	2,350,620.00	78,365.89	2,272,254.11	23,736,221.81	279,605.32	23,456,616.49	99%



Department of Water, County of Kauai
 Monthly Budget Summary vs. Actual
 10
 9/30/2020

	September				FY 2021			
	Original Budget	Revised Budget	Actual	Variance	Revised YTD Budget	YTD Actual	*Variance	Variance %
Capital Projects (See Attached for Details):								
10-02-00-604-999 WU-IT-RandR Capital Purchases--	9,359.00	9,359.00	9,374.93	(15.93)	211,817.34	10,266.92	201,550.42	95%
10-02-00-605-999 WU-IT-Expansion Capital Purchases--	13,333.00	13,333.00	31.41	13,301.59	64,942.47	11,012.53	53,929.94	83%
10-10-40-604-999 WU-QualRandR Capital Purchases	3,333.00	3,333.00		3,333.00	9,999.00		9,999.00	100%
10-20-00-604-001 WU-Eng-ALLR-17-10-KW-07 Paua Valley Tank Repair	7,083.00	7,083.00		7,083.00	38,519.12		38,519.12	100%
10-20-00-604-132 WU-Eng-ALLR-13-05 Kolo Rd Main Replacement					2,712.50		2,712.50	100%
10-20-00-604-138 WU-Eng-69%R-11-07 HE-03 Hanapepe & Koloa Well MCC					24,467.50		24,467.50	100%
10-20-00-604-146 WU-Eng-12%R-Job 15-7 HE-01&10HanapepeEleeeConn PL					3,426.68		3,426.68	100%
10-20-00-604-148 WU-Eng-56%R-Kuhio Hwy Hardy-Oxford 16IN Main Repla					171,593.09	8,148.07	163,445.02	95%
10-20-00-604-157 WU-Eng-16-4-WKK-03-Kilauea Wells MCC Rehab	20,833.00	20,833.00		20,833.00	129,362.70		129,362.70	100%
10-20-00-604-160 Job 18-02 Islandwide Rehabilitation of Tanks					346,218.15		346,218.15	100%
10-20-00-604-164 WU-Eng-Job. 18-9 Makaleha Tunnel					229,632.00		229,632.00	100%
10-20-00-604-999 WU-Eng-RandR Capital Purchases	833.00	833.00	804.00	29.00	2,499.00	925.00	1,574.00	63%
10-20-00-605-139 WU-Eng-ALLE-02-11 M-02 100K Tank & Pipeline Moloaa					125,200.00		125,200.00	100%
10-21-00-604-001 Job 17-10 KW-07 Paua Valley Tank Repair					2,375,000.00	107,541.25	2,267,458.75	95%
10-21-00-604-029 WU-Cns-44%R-09-01 Yamada Tank Clearwell, Conn Pipe	1,100,000.00	1,100,000.00		1,100,000.00	3,300,000.00		3,300,000.00	100%
10-21-00-604-146 Job 15-07 HE-01 HE-10 Kaunualii Hwy 16" Main Boost					4,931,895.55		4,931,895.55	100%
10-21-00-604-157 Job 16-4 WKK-03-Kilauea Wells MCC Rehab	312,917.00	312,917.00		312,917.00	938,751.00		938,751.00	100%
10-21-00-604-167 WU-CM-R&R-Kukuilono Tank Demo	62,500.00	62,500.00		62,500.00	187,500.00		187,500.00	100%
10-21-00-604-999 WU-CM-RandR Capital Purchases	833.00	833.00		833.00	2,499.00		2,499.00	100%
10-21-00-605-017 Job 16-02 PLH-35B Kapaia Cane Haul Rd 18" Main					3,195,675.00		3,195,675.00	100%
10-21-00-605-118 Job 02-14 WK39 WK08 Kapaa Hmstd Well 4; Pkg A Well					603,660.83		603,660.83	100%
10-21-00-605-146 Job 15-07 HE-01 HE-10 Kaunualii Hwy 16" Main Boost					125,231.08		125,231.08	100%
10-21-00-605-999 WU-CM-Expansion Capital Purchases	833.00	833.00		833.00	2,499.00		2,499.00	100%
10-30-00-604-999 WU-Bill-RandR Capital Purchases	13,250.00	13,250.00		13,250.00	39,750.00		39,750.00	100%
10-40-00-604-166 WU-Operations-R&R-SWTP Delivery Agreement-GroveFar	183,496.00	183,496.00		183,496.00	550,488.00		550,488.00	100%
10-40-00-604-999 WU-Ops-RandR Capital Purchases	64,250.00	64,250.00	7,597.97	56,652.03	527,336.95	39,403.97	487,932.98	93%
10-40-00-605-999 WU-Ops-Expansion Capital Purchases	1,517.00	1,517.00	59,057.58	(57,540.58)	480,598.91	59,057.58	421,541.33	88%
Total Capital Projects (See Attached for Details)	1,794,370.00	1,794,370.00	76,865.89	1,717,504.11	18,621,274.87	236,355.32	18,384,919.55	99%



Department of Water, County of Kauai
 Monthly Budget Summary vs. Actual
 20
 9/30/2020

	<u>September</u>				<u>FY 2021</u>			
	<u>Original Budget</u>	<u>Revised Budget</u>	<u>Actual</u>	<u>Variance</u>	<u>Revised YTD Budget</u>	<u>YTD Actual</u>	<u>*Variance</u>	<u>Variance %</u>
Capital Projects (See Attached for Details):								
20-20-00-605-117 FRC-Eng-ALLE-12-02 WK-23 UH Expmntal Storage Tank					26,832.00		26,832.00	100%
20-20-00-605-118 Job 04-08 WK-39 Drill Kapaa Homestead Well 4	37,500.00	37,500.00		37,500.00	193,426.50		193,426.50	100%
20-20-00-605-120 FRC-Eng-90%E-Kilauea 1.0MG Tank Job 02-06					7,212.24		7,212.24	100%
20-20-00-605-153 Job 15-08-HW-11-Haena 0.2MG Tank					58,672.48		58,672.48	100%
20-20-00-605-154 Job 17-11 Drill & Test Kilauea Well #3					297,240.00		297,240.00	100%
20-21-00-605-161 FRC-Cns-Hanapepe River Bridge Kaunualii Hwy	18,750.00	18,750.00		18,750.00	56,250.00		56,250.00	100%
Total Capital Projects (See Attached for Details)	56,250.00	56,250.00		56,250.00	639,633.22		639,633.22	100%



Department of Water, County of Kauai
 Monthly Budget Summary vs. Actual
 30
 9/30/2020

	September				FY 2021			
	Original Budget	Revised Budget	Actual	Variance	Revised YTD Budget	YTD Actual	*Variance	Variance %
Capital Projects (See Attached for Details):								
30-20-00-604-105 BAB-Eng-ALLR-09-01 K-01 Kalaheo 1111FT & 1222FT					332,924.26		332,924.26	100%
30-20-00-605-120 BAB-Cns-ALLE-02-06WKK15-Kilauea 466 Tank Puu Pane					22,649.00		22,649.00	100%
30-20-00-605-125 BAB-Eng-98%E-02-01 Land for Kukuioolono Tank Site					53,508.05		53,508.05	100%
30-20-00-605-139 BAB-Eng-ALLE-02-11 M-02 100K Tnk & Pipeline Moloaa					94,222.00		94,222.00	100%
30-21-00-604-017 Job 16-02 PLH-35B Kapaia Cane Haul Rd 18" Main					1,091,650.00		1,091,650.00	100%
30-21-00-604-107 Job 11-07 KP-09-MCC Chlor KoloaWell16-A,B,E					1,323,634.55		1,323,634.55	100%
30-21-00-605-029 BAB--09-01 Yamada Tank Clearwell, Conn Pip	500,000.00	500,000.00		500,000.00	1,500,000.00		1,500,000.00	100%
30-21-00-605-118 Job 04-08 WK39 WK08 Kapaa Hmstd Well 4; Pkg A Well			1,500.00	(1,500.00)	56,725.86	43,250.00	13,475.86	24%
Total Capital Projects (See Attached for Details)	500,000.00	500,000.00	1,500.00	498,500.00	4,475,313.72	43,250.00	4,432,063.72	99%

III.

BILLED REVENUES COMPARATIVE REPORT
For Fiscal Years 2019, 2020 & 2021

		<u>2019</u>		<u>2020</u>		<u>2021</u>		Cum. Inc (Dec)	% Inc. (Dec.)
July	\$	2,459,791	\$	2,594,993	\$	2,399,952	\$	(195,041)	-7.52%
August	\$	4,944,154	\$	5,211,518	\$	4,528,656	\$	(682,862)	-13.10%
September	\$	7,331,598	\$	7,780,505	\$	6,873,259	\$	(907,246)	-11.66%

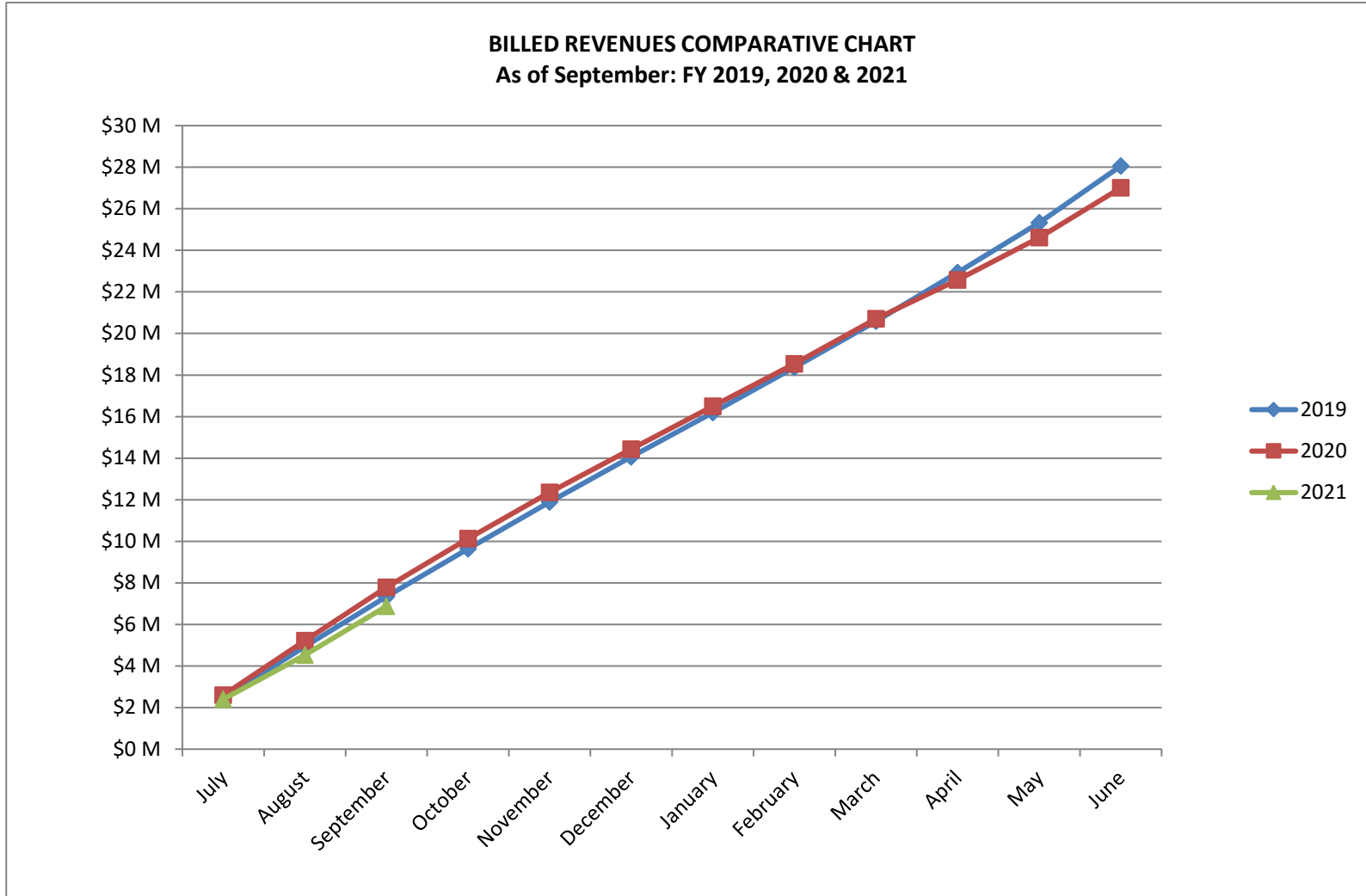

CASH RECEIPTS (W/U) COMPARATIVE REPORT
For Fiscal Years 2019, 2020 & 2021

		FY 2019	FY 2020	FY 2021	Cum. Inc (Dec)	% of Inc (Dec)
July	\$	2,449,372	\$ 3,035,518	\$ 2,368,257	(667,261)	-22%
August	\$	4,946,100	\$ 7,676,802	\$ 4,578,257	(3,098,545)	-40%
September	\$	7,122,906	\$ 10,216,754	\$ 6,808,747	(3,408,007)	-33%

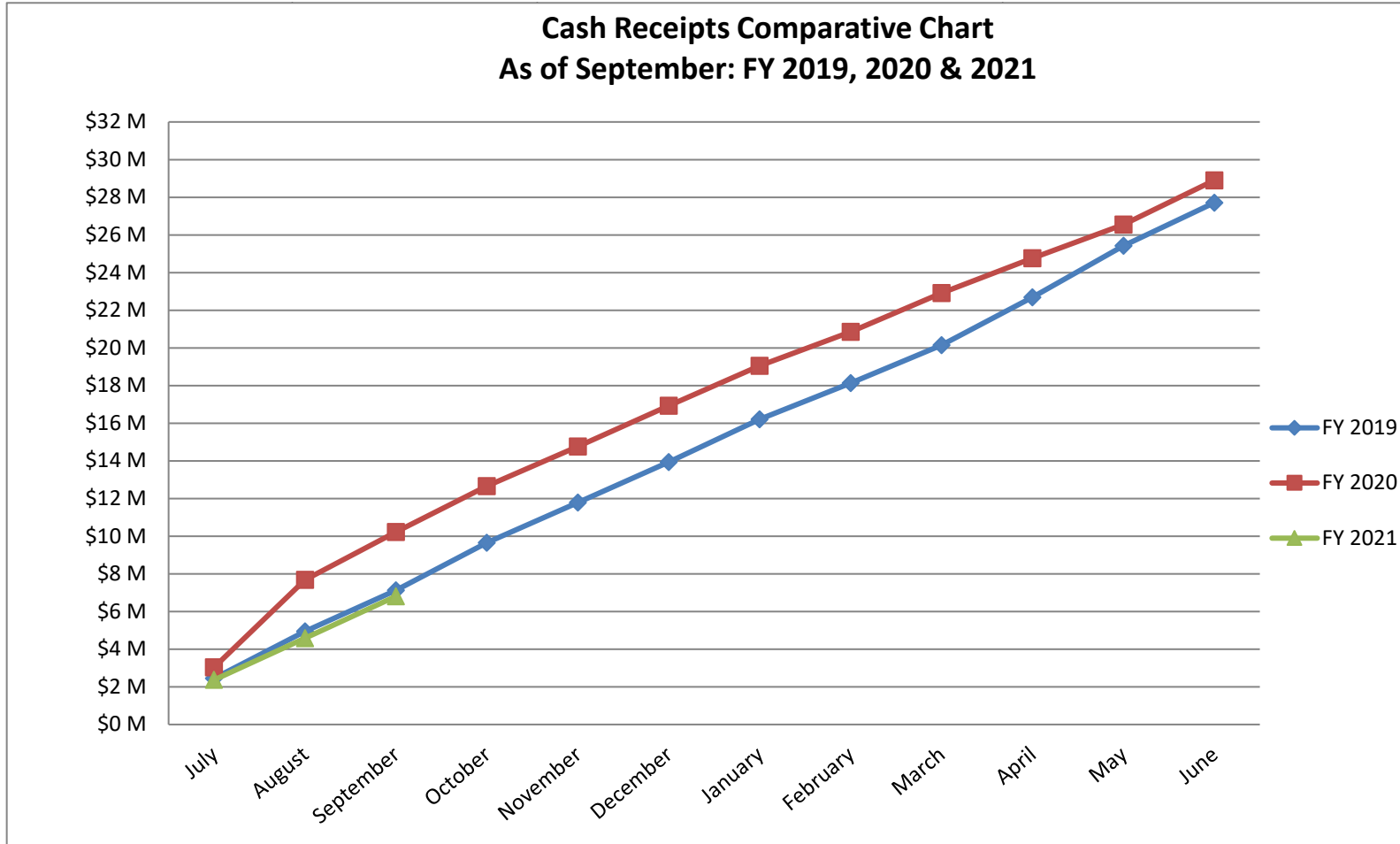

* Note: July '19-'20 receipts included a \$2.29 million state appropriation grant for the Hanapēpē.....

METERED CONSUMPTION (000 GALLONS) MONTHLY COMPARATIVE CHART
 For Fiscal Years 2019, 2020 & 2021
 (expressed in thousands)

	<u>FY 2019</u>	<u>FY 2020</u>	<u>FY 2021</u>	<u>MONTHLY INC. (DEC.)</u>	
July	436,238	365,892	335,209	-30,683	-8%
August	361,599	362,067	295,297	-66,770	-18%
September	415,176	369,751	329,858	-39,893	-11%

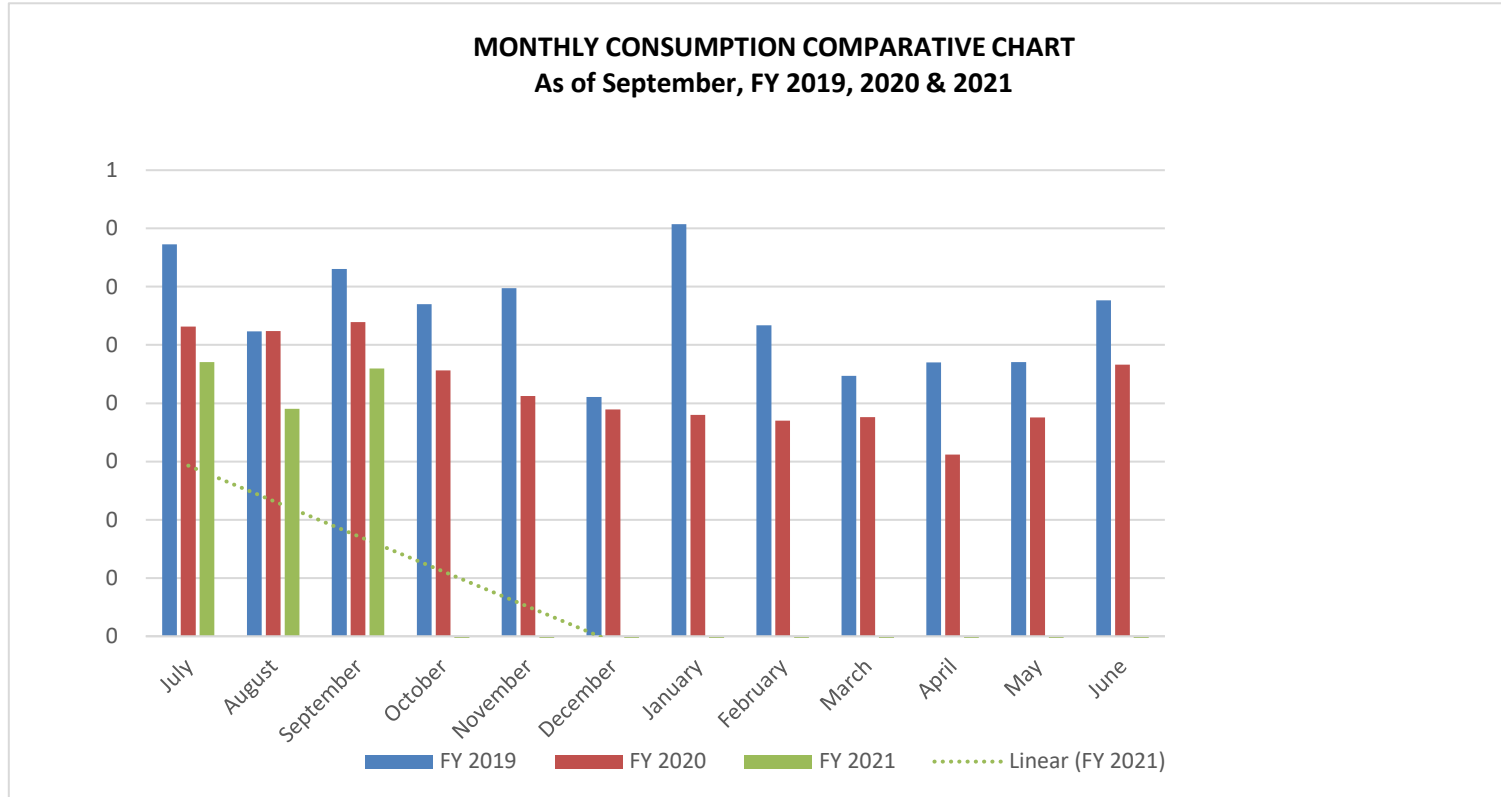

YTD METERED CONSUMPTION (000 GALLONS) COMPARATIVE REPORT
 For Fiscal Years 2019, 2020 & 2021
 (expressed in thousands)

	<u>FY 2019</u>	<u>FY 2020</u>	<u>FY 2021</u>	<u>CUM. INC (DEC)</u>	<u>%</u>
July	344,364	365,892	335,209	-30,683	-8%
August	692,933	727,959	630,506	-97,453	-13%
September	1,018,284	1,097,710	960,364	-137,346	-13%

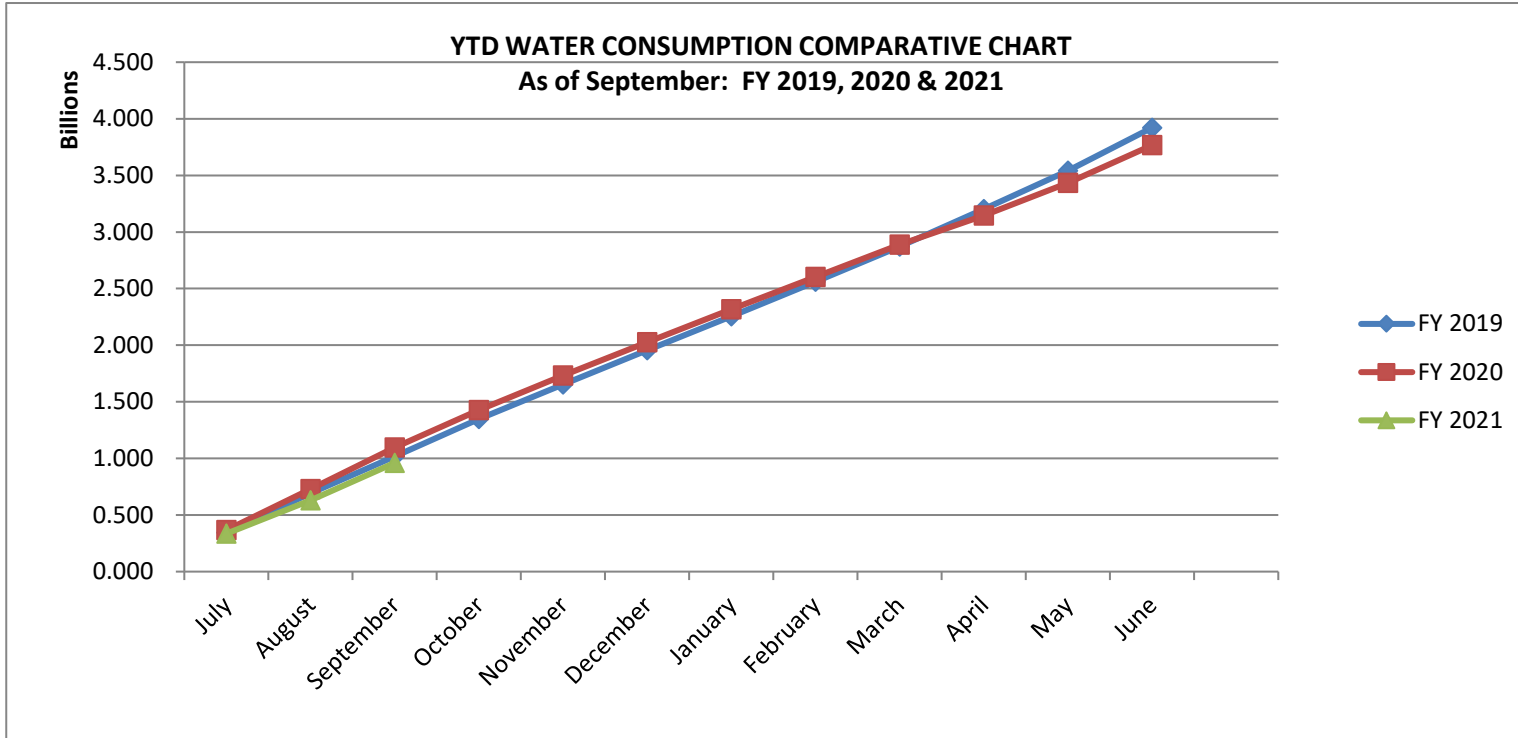

DEPARTMENT OF WATER
Accounts Receivable Aging Summary
As of September, 2020

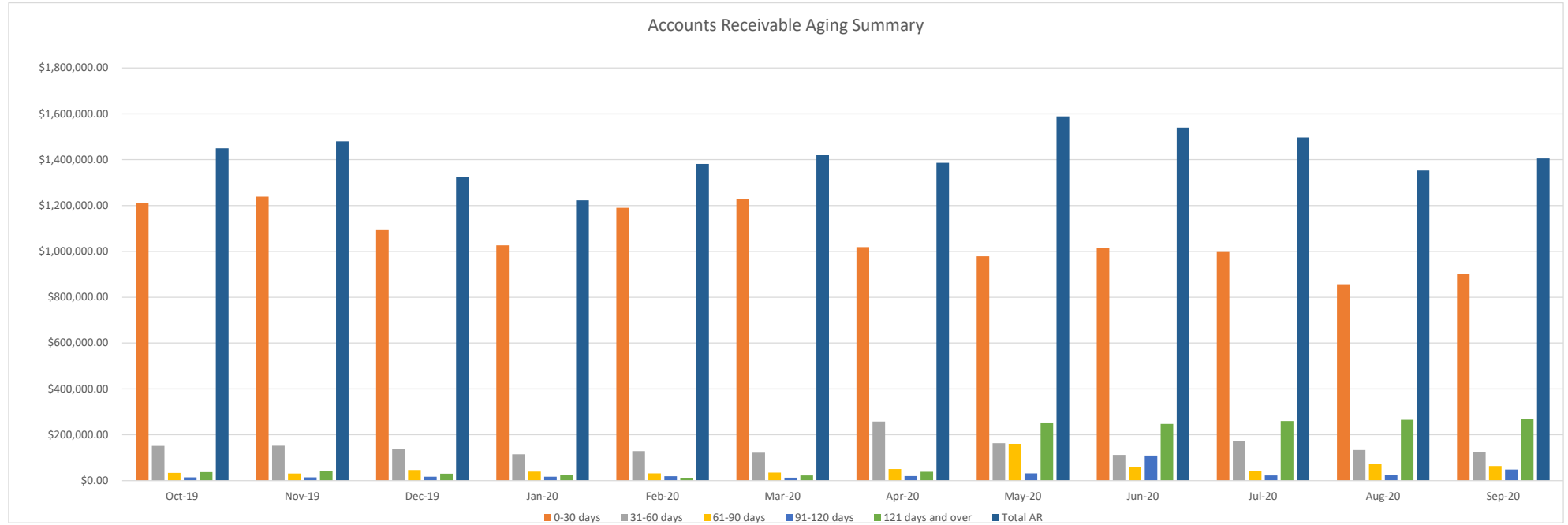

AR Aging	Oct-19		Nov-19		Dec-19		Jan-20		Feb-20		Mar-20		Apr-20		May-20		Jun-20		Jul-20		Aug-20		Sep-20	
0-30 days	\$1,211,614.04	84%	\$1,238,572.50	84%	\$1,093,337.19	83%	\$1,026,241.32	84%	\$1,189,752.20	86%	\$1,229,258.09	86%	\$1,018,686.24	73%	\$978,907.17	62%	1,013,853.91	66%	\$997,485.31	67%	\$856,561.14	67%	900,031.84	64%
31-60 days	\$151,924.87	10%	\$152,570.76	10%	\$137,197.13	10%	\$115,140.84	9%	\$128,662.63	9%	\$121,758.30	9%	\$257,987.42	19%	\$163,475.93	10%	112,069.52	7%	174,030.47	12%	133,850.15	12%	\$123,235.43	9%
61-90 days	\$33,854.98	2%	\$31,100.40	2%	\$46,080.54	3%	\$39,702.40	3%	\$31,954.93	2%	\$35,486.34	2%	\$50,532.72	4%	\$160,891.80	10%	57,755.74	4%	42,403.40	3%	70,980.66	3%	\$63,689.26	5%
91-120 days	\$14,639.21	1%	\$14,451.96	1%	\$17,301.17	1%	\$17,200.37	1%	\$18,953.24	1%	\$13,058.29	1%	\$20,047.89	1%	\$31,925.61	2%	109,465.82	7%	22,617.26	2%	26,277.91	2%	\$48,398.78	3%
121 days and over	\$37,349.21	3%	\$42,761.86	3%	\$30,389.69	2%	\$24,330.48	2%	\$12,326.29	1%	\$22,886.96	1%	\$38,823.06	3%	\$253,754.60	16%	247,167.20	16%	259,985.17	17%	265,096.96	17%	269,845.15	19%
Total AR	\$1,449,382.31	100%	\$1,479,457.48	100%	\$1,324,305.72	100%	\$1,222,615.41	100%	\$1,381,649.29	100%	\$1,422,447.98	100%	\$1,386,077.33	100%	\$1,588,955.11	100%	\$1,540,312.19	100%	\$1,496,521.61	100%	\$1,352,766.82	100%	\$1,405,200.46	100%

*Total AR is net of Customer deposits and overpayments.

Customer Deposits & Overpayments	(\$205,885.03)	(\$196,263.56)	(\$209,366.49)	(\$216,003.50)	(\$231,033.54)	(\$219,423.13)	(\$207,346.51)	(\$179,741.24)	(\$235,645.43)	(\$228,641.66)	(\$233,729.73)	(\$231,853.92)
----------------------------------	----------------	----------------	----------------	----------------	----------------	----------------	----------------	----------------	----------------	----------------	----------------	----------------

DEPARTMENT OF WATER

County of Kaua'i

"Water has no Substitute – Conserve it!"

INFORMATION & EDUCATION SPECIALIST REPORT

October 22, 2020

Public Notices and Announcements

All news releases were also published on the Department's Facebook social media page and online at www.kauai.gov/press-releases.

- **Lihue-Kapa'a – Supplemental water source back online**
 - A news release was issued on September 22, 2020 to inform customers that the surface water treatment plant was back online and will be supplementing water service to customers connected to the DOW's Lihue-Kapa'a water system and began servicing customers effective Sept. 22nd. There are no advisories or customer action required at this time.
- **Hanapepe – Water service shutdown and conservation request scheduled**
 - A news release was issued on September 22, 2020 to announce a water service shutdown scheduled for a portion of Hanapepe Road; between Ko Road and Hana Road, and includes approximately 4 customers on Kona Road in Hanapepe. Water service will be turned off on Tuesday, September 29th from 8 a.m. to 4 p.m.; weather permitting, in order to connect a new 6-inch main line to the existing 12-inch main and relocate 2 service meters as part of the Hanapepe-Ele'ele Water Systems Improvements Project.
 - A courtesy notice was also issued to the affected service area via BlackBoard Connect mass notification service.
 - A public service announcement was also submitted to Hanapepe town association members and to local radio stations for on-air announcements.
 - A news release was issued on September 28, 2020 to issue a water conservation request for customers on the Hanapepe – Ele'ele water system scheduled on September 29, 2020 from 8 a.m. to 4 p.m.; to coincide with the schedule water service shutdown and installation work on Hanapepe Road in Hanapepe.
 - A courtesy notice was also issued to the affected service area via BlackBoard Connect mass notification service.
 - A reminder news release was issued on September 28, 2020 to announce the water service shutdown in Hanapepe town on September 29 from 8 a.m. to 4 p.m., weather permitting.
 - A courtesy notice was also issued to the affected service area via BlackBoard Connect mass notification service.
 - A public service announcement was also submitted to Hanapepe town association members and to local radio stations for on-air announcements.
- **All Systems – Free water education activity kit distribution for IADWW**
 - A news release was issued on September 28, 2020 to announce a drive-thru distribution of free water education activity kits for keiki and their families on Tuesday, Oct. 6th from 9 a.m. to 10 a.m. at the Vidinha Stadium parking lot in Lihue. The free water education event is part of the DOW's celebration of the national Imagine a Day Without Water awareness campaign

- The news release was published in the Garden Island Newspaper on October 5, 2020 entitled “Imagine a Day Without Water”. (*Attached*).
- A post-event news release was issued on October 6, 2020 to promote the Department’s successful distribution of over 520 activity kits to the community. The article also highlighted the Department’s Facebook campaign and invited followers to take part in the Value Water Challenge online.
 - The Department was featured as the front-page article in the Wednesday, Garden Island Newspaper on October 7, 2020; entitled “Imagine a Day Without Water” written by Dennis Fujimoto and featured post event information and event photos (*Attached*).
- Kapa’a – Emergency water service shutdown
 - A news release was issued on October 6, 2020 to announce an emergency water service shutdown on Hekili Road in Kapa’a for approximately 4 to 5 hours due to a recently damaged main line.
 - A courtesy notice was also issued to the affected service area via BlackBoard Connect mass notification service.
- Wainiha – Scheduled Water Service shutdown
 - A news release was issued on October 9, 2020 to announce a scheduled water service shutdown on October 12, 2020 from 10 a.m. to 2 p.m., weather permitting in order to conduct repairs to a distribution line on Kuhio Highway. Intermittent traffic control was also scheduled on the Wainiha bridge during the scheduled work.
 - A courtesy notice was also issued to the affected service area via BlackBoard Connect mass notification service.

Public Relations Program

Community Outreach & Education

- Public Relations staff (PR) have been progressive in the improvement and increase of direct communications with customers; by providing courtesy calls, assisting divisions with information dissemination, social media posts/responses and by issuing additional notices regarding service disruptions, service inquiries, etc. *On-going*.
- PR hosted a water education activity kit distribution event on October 6, 2020 at the Vidinha Stadium parking in Lihue. The free drive-thru contact-less event received a healthy response from the community. Over 520 kits were distributed to families and teachers, as an effort to promote water conservation, water education and engage in community outreach efforts during covid-19 related closure. Educational activity kit included a logo water bottle, shower timer, Project WET activity book, DOW logo school supplies, low-flow fixtures and informational department brochures. The event was held as a community effort to promote the Imagine a Day Without Water campaign. Special thanks to our Department staff: Terrilyn Amorin, Jason Fujinaka, Jonelle Taira-Kakutani, Ferdinand Mariano, Carl Arume, Peggy Yoshioka, Edie Ignacio-Neumiller, Bekki-Dee Malapit, Mahealani Krafft, Kevin Pongasi, Dan Kittredge, Chris Caoagas, Malia Reis, Jonell Kaohelaulii, Claus Bollman and Boardmember Gregory Kamm for their participation and volunteerism that helped to make this new event a success.
 - The Department received 2 featured articles in the Garden Island Newspaper for this event; published on October 5, 2020 and a post-event article published on October 7, 2020, titled “Imagine a Day Without Water (*Attached*)”.

- The Imagine a Day Without Water online Facebook campaign continues through Oct. 21st. Daily posts featuring water educational messaging and informative water service videos began Oct. 1 and will continue thru the 21st. Posts will include new Facebook videos, community interviews and shared posts from partnering water agencies.

Upcoming Community Outreach & Educational Events

- October 1-21, 2020 – Imagine a Day Without Water (online campaign)

Project WET Hawaii

- Project WET Hawaii continues to prepare for the temporary transition to virtual workshops for educators and facilitator trainings, tentatively planned to begin in January 2021. PR is working on obtaining online meeting tools, appropriate software, supplies and is also working with regional coordinators for idea sharing and additional resources. Project WET Hawaii has received 3 requests for educator trainings to help support agencies with distance learning appropriate activities. *On-going.*

Miscellaneous

- PR is assisting coordination for DOW employee participation in the County's Employee Council Spooktacular event in late October. The event will include a themed display and sponsorship of water conservation tools for the event.

JK/ein

Attachments:

- *Garden Island (Imagine a Day Without Water, October 5, 2020*
- *Garden Island (Imagine a Day Without Water, October 7, 2020*

Mgrrp/October 2020/Information & Education Specialist Report (10-22-20);ein

Hawaii News

'Imagine a Day Without Water'

By [The Garden Island](#) | Monday, October 5, 2020, 12:05 a.m.

Share this story [f](#) [t](#) [e](#)



Contributed

County Department of Water staff members distribute water-conservation kits to students in Waimea.

-continued-

**BUY HAWAI'I
COUNTY BONDS**



For more information
call your broker or visit
hawaiicounty.gov/bonds

This ad is not an offer to sell nor a solicitation of an offer to buy bonds. Bonds may only be purchased through a registered broker.

LIHUE — The county Department of Water is offering a drive-thru distribution of free water-education-activity kits for keiki and their families on Tuesday, Oct. 6, from 9 to 10 a.m. at Vidinha Stadium in Lihu'e.

The water-education event is part of the DOW's celebration of the national Imagine a Day Without Water awareness campaign. No registration is required, and kits will be distributed on a first-come, first-served basis.

"The water-activity kits are a great way to introduce water education during fall break," said Jason Fujinaka, DOW information specialist. "We invite students and their families to pick up a free kit during the event to learn more about the importance of water in our everyday lives."

The water-education-activity kits include a Project WET (Water Education Today) activity booklet with interactive water lessons, a five-minute shower timer, a collapsible water bottle, low-flow household fixtures, a notebook and other fun supplies.

Additionally, DOW is hosting a special Facebook campaign in October, featuring educational IADWW-related posts, and a value water challenge. All water users are invited to take the value water challenge on Facebook by sharing a video or written post, answering the question: Why is water important to you?

Participants of the challenge may include the hashtags #ValueWaterKauai and #IADWWKauai on their post for a chance to be seen and featured on the DOW's Facebook page at facebook.com/KauaiDOW.

Imagine a Day Without Water is celebrated nationally on Oct. 21 and is led by the Value Water Campaign as an opportunity for diverse organizations, from environmental advocates to coffee shops, developers to farmers, local fishermen to public water utilities, to talk about what and why water is important to them.

This year, DOW joins a statewide team of IADWW participants to host Facebook events on Oct. 21. Learn more at imagineadaywithoutwater.org and follow the national conversation on social media at #ValueWater.

For more information about the water-education-activity kits giveaway, call the DOW 245-5455 or email publicrelations@kauaiwater.org.

###

Published in the Garden Island Newspaper on 10-07-2020

'Imagine a Day Without Water'

By [Dennis Fujimoto The Garden Island](#) | Wednesday, October 7, 2020, 12:05 a.m.

Share this story   



Dennis Fujimoto / The Garden Island

Malia Reis of the county Department of Water hands out a free water-education kit Tuesday during the "Imagine a Day Without Water" giveaway at Vidinha Stadium in Lihue.

-continue-

LIHU'E — Washing hands with soap and running water is one of the controls in the spread of the novel coronavirus.

How would this be done in “Imagine a Day Without Water?”

Earlier in the school year, the COVID-19 caused the cancellation of the county Department of Water Project WET (Water Education Today) Make A Splash water-education event for hundreds of fourth-grade students on the island.

“We had to cancel the Make A Splash event because of the pandemic,” said Jonell Kaohelauli'i, the DOW spokesperson. “That meant stepping up our community-outreach efforts. This free water-education-activity kit is just part of that increased effort where we already distributed more than a hundred kits to the Boys & Girls Club of Hawai'i. We have a lot more for people driving through.”

The drive-thru effort is part of the DOW's celebration of the national Imagine a Day Without Water event observed nationally on Oct. 21.

Imagine a Day Without Water recognizes the essential efforts done by water and wastewater systems to keep clean water flowing throughout the days of the threat from the novel coronavirus pandemic. Led by the Value Water Campaign, Imagine a Day Without Water also is an opportunity for everyone to talk about what and why water is important.

-continue

Kaua'i County Councilmember Luke Evslin, a bottle of cold water strapped around his waist during his morning bicycle ride with his son, was one of the first to stop for the free activity kit.

"The water-activity kits are a great way to introduce water education during the fall break," said Jason Fujinaka, DOW information specialist. "Students and their families learn about the importance of water in our everyday lives by participating in the interactive activities."

The free kits included a Project Water Education Today activity booklet with interactive water lessons, a five-minute shower timer, a collapsible water bottle, low-flow household fixtures including a showerhead and kitchen faucet aerator, a notebook, pencils and other supplies packed in a reusable backpack.

In addition to the activity-kit giveaway, the DOW is hosting a special Facebook campaign through the month of October, featuring educational Imagine a Day Without Water-related posts, and a Value Water Challenge.

All water users are invited to take the Value Water Challenge on Facebook by sharing a video, or written post, answering the question, "Why is water important to you?"

Participants in the challenge may include the hash tags #ValueWaterKauai, and #IADWWKauai on their post for an opportunity to be seen and featured on the DOW Facebook page, [facebook.com/KauaiDOW](https://www.facebook.com/KauaiDOW).

...

DEPARTMENT OF WATER

County of Kaua'i

"Water has no Substitute – Conserve It!"

Operations Division Report for the Month of September 2020

Personnel

- Operations personnel attended Fork Lift certification classes and Driver Safety Classes with the Department of Human Resources.

Source and Storage

- Maintenance workers continued cleaning various remote facilities island-wide. Works included clearing of vegetation and drainage as well as repair and construction of structures and facilities including access driveways.
- Water Plant Operators performed routine inspection and maintenance at all sites including valve maintenance, piping repair and replacement, chlorination equipment maintenance, and mixing of sodium hypochlorite.
- Department of Health, Safe Drinking Water Branch conducted sanitary survey of Puhi to Kapaa Water System.
- Job-20-05 Waimea Well B Repair awarded to low bidder and award was posted.
- Contract No. 699 for Kapilimao On-Site Sodium Hypochlorite Generation was executed and Notice To Proceed issued.
- Monitoring of Sodium Hypochlorite on-site generation equipment on Makaleha Wells and Tank Site is on-going.
- Electrical workers performed routine electrical maintenance at all sites including SCADA radio troubleshooting, electrical wiring for motor controls, lighting repair and replacement.
- SCADA Contract No. 701 with Glenmount Global Services is being processed.
- Auto mechanics performed routine maintenance of all DOW vehicle and equipment including light, medium and heavy vehicles as well as construction equipment and generators.

Distribution

- Operations Division Field Section crews continue to perform routine leak repair of service laterals and mainlines. Field Section personnel responded to forty four (44) leak repair work orders.
- Field Section personnel installed a service lateral.
- We received a total of 136 calls from customers reporting leaks on the mainline, service laterals, meters, meter boxes and fire hydrants including complaints of no water, complaints of low pressure, high pressure, calls requesting remote site/facility grounds and vegetation maintenance, calls for assistance in shutting off the water meter, calls reporting damaged meter box and cover, reports of leaking or damaged fire hydrants and report of white milky water, and non-water emergency calls mainly customer inquiries. Work orders were generated and all calls resolved. Leak after the meter needs to be addressed by the customer.
- Three service laterals were installed along with five new water meters.
- Operations Division received two (2) emergency calls for hydrants hit by vehicle.
- Relative to the Board's request regarding where we stand on the water audit compared with industry standard, we checked with Hawaii Commission on Water Resource Management (CWRM) and were provided the following key performance indicator results for calendar year 2018:

	Median Apparent Losses/Con./Day (Gal.)	Median Real Losses/Con./Day (Gal.)	Median Real Losses/Length of Main/Day (Gal.)	Infrastructure Leakage Index (ILI)
KDOW	10.039	52.552	4563.783	2.398
All Four Counties	24.163	56.177	1654.669	2.405

ILI = Current Annual Real Losses/Unavoidable Annual Real Losses

Apparent Losses = unauthorized consumption + customer metering inaccuracies + systematic data handling errors

Real Losses = leaks, breaks, and tank overflows.

Fleet, Inventory, Warehouse and Baseyard Area

- Three hundred seventy nine (379) work orders were issued for Operations Division. Works included: electrical repairs and maintenance; automotive repairs and maintenance including power generator maintenance; Hawai'i One Call requests for markings; water meter installation and replacement; service lateral installations; leak repairs; well, tank

site and PRV maintenance; replace damaged meter boxes; repair defective meters; replace damaged or leaking hydrant; door-to-door customer notifications for tie-ins of new lines to existing lines as well as notifications regarding scheduled repairs; callouts due to customer complaints/reports; meter replacement requests; Hawai'i One Call relative to contractor's requests for markings.

- Thirty two (32) Hawai'i One Call requests for markings were received. Twenty three (23) meters were maintained, replaced, repaired, issued and installed.
- Four unusable vehicles CK 1958, CK1888, CK1678, CK2049, that are unsafe for auctioning were sent to Resource Recovery Solutions, LLC formerly Puhi Metals Recycling.

VPR/ein

Attachments: Overtime Chart
Leak Report Chart
Production/Billing Chart

Mgrrp/October 2020/Operations Division Report for the Month of September 2020 (10-22-20):ein

County Of Kauai - DEPARTMENT OF WATER
 Operations Division: Plant & Field
 Total Hours for the Month
 For the Period: January 2015 to September 2020

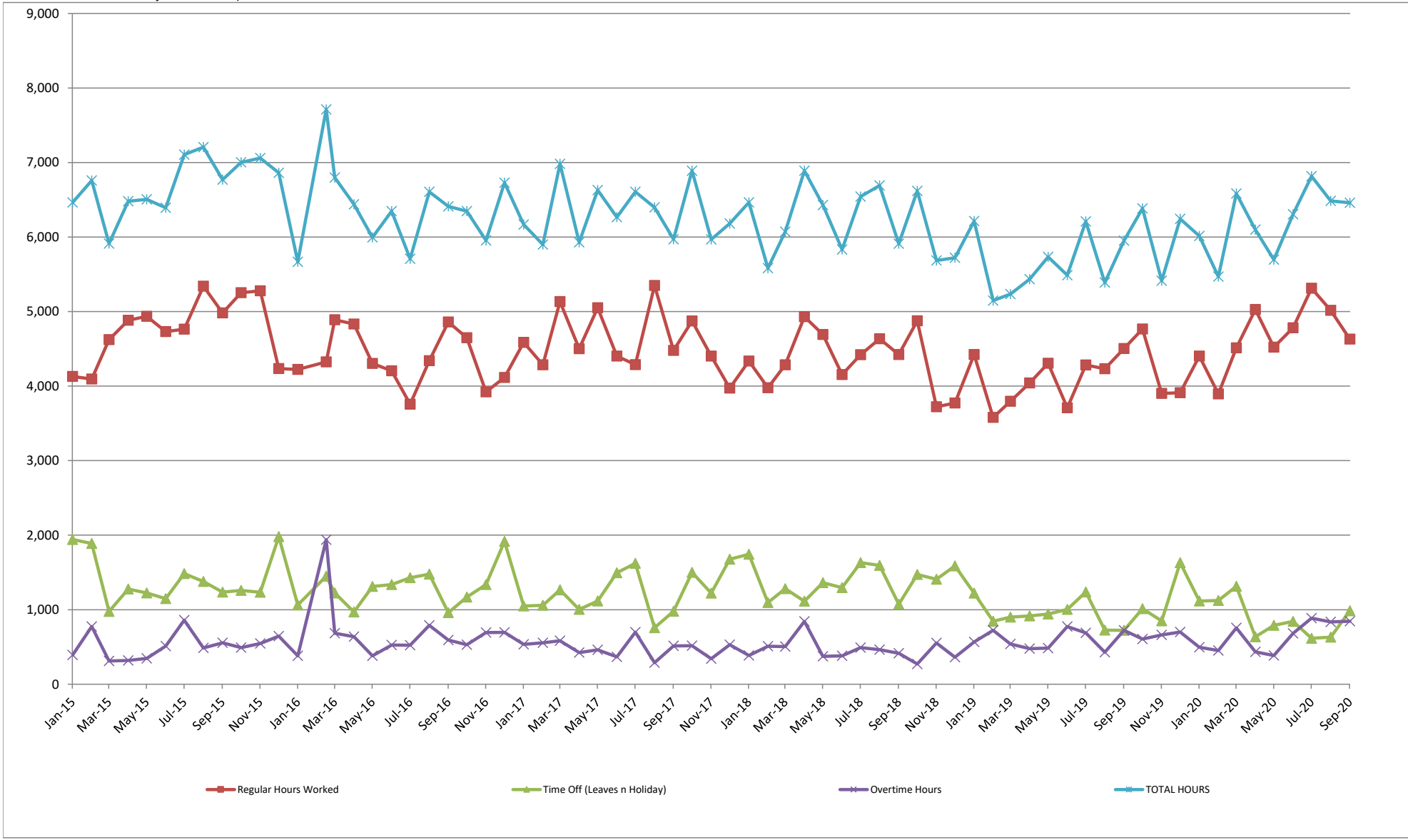

Work Orders by Job Reason Code for Selected Date Range

09/01/2019 to 09/30/2020

# of W/O's	Job Reason Code	Description
19	LEAK-BOX	Meter Box Leak Repair
44	LEAK-CALOU	LEAK CALL OUT
2	LEAK-CUST	Customer-Side Leak Repair
84	LEAK-MAIN	Mainline Leak Repair
99	LEAK-S/L	Service Lateral Leak Repair

Work Orders by Job Reason Code

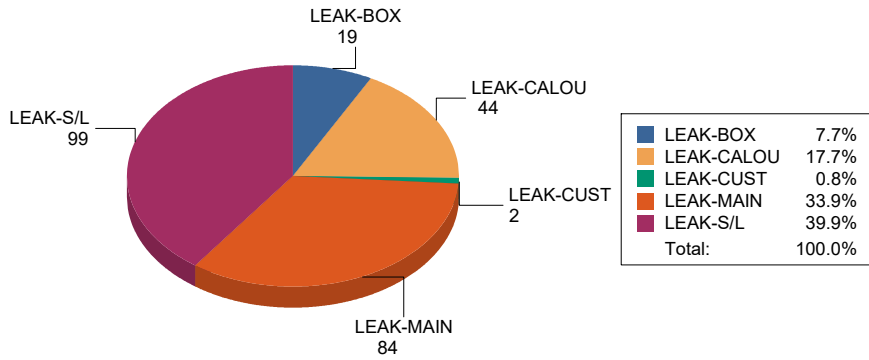

Work Orders by Job Reason Code for Selected Date Range

09/01/2019 to 09/30/2020

of W/O's Job Reason Code Description

Number of Leak Repairs per Month

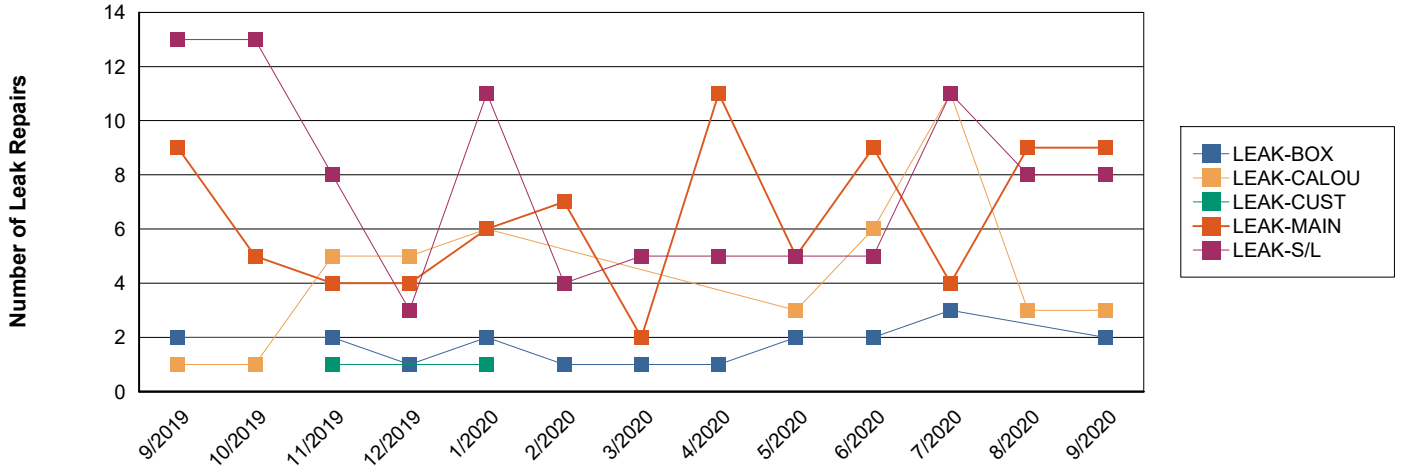

Monthly Water Produced, Customer Meter Read and Waterloss Comparison For Calendar Year 2019/2020

	Sep-19	Oct-19	Nov-19	Dec-19	Jan-20	Feb-20	Mar-20	Apr-20	May-20	Jun-20	Jul-20	Aug-20	Total Year
Produced (Kgals.)	388,079	353,485	354,625	345,277	342,849	334,596	308,281	309,984	370,458	393,627	331,959	358,841	4,192,058
Customer Meter Read (Kgals.)	324,640	304,152	306,129	282,869	283,286	293,740	253,258	287,536	327,214	334,303	293,457	322,898	3,613,482
Waterloss (kgals.)	63,439	49,333	48,496	62,408	59,563	40,856	55,023	22,448	43,244	59,324	38,502	35,943	578,576
Waterloss (%)	16.3	14.0	13.7	18.1	17.4	12.2	17.8	7.2	11.7	15.1	11.6	10.0	13.8
Waterloss (\$)	81,011	62,998	61,929	79,695	76,061	52,173	70,264	28,666	55,222	75,757	49,166	45,899	738,842
Waterloss (gal/con/day)	89.00	66.98	68.04	84.73	80.87	61.41	74.71	31.49	58.71	83.23	52.27	48.80	66.72

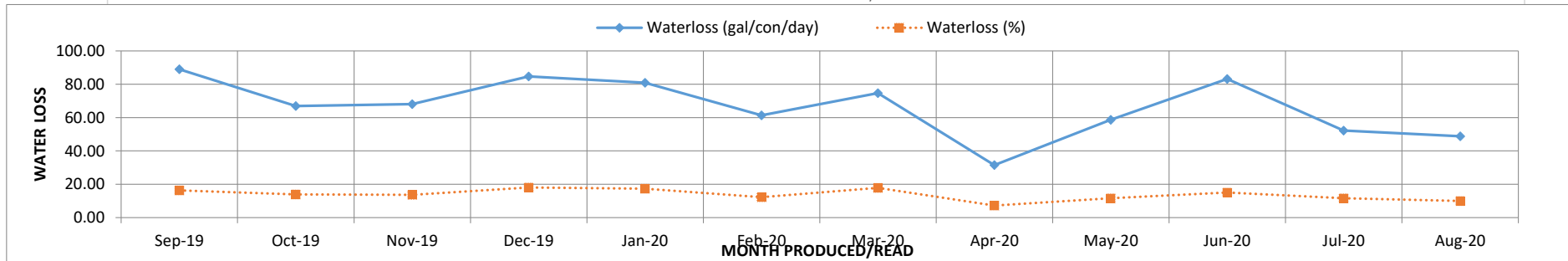
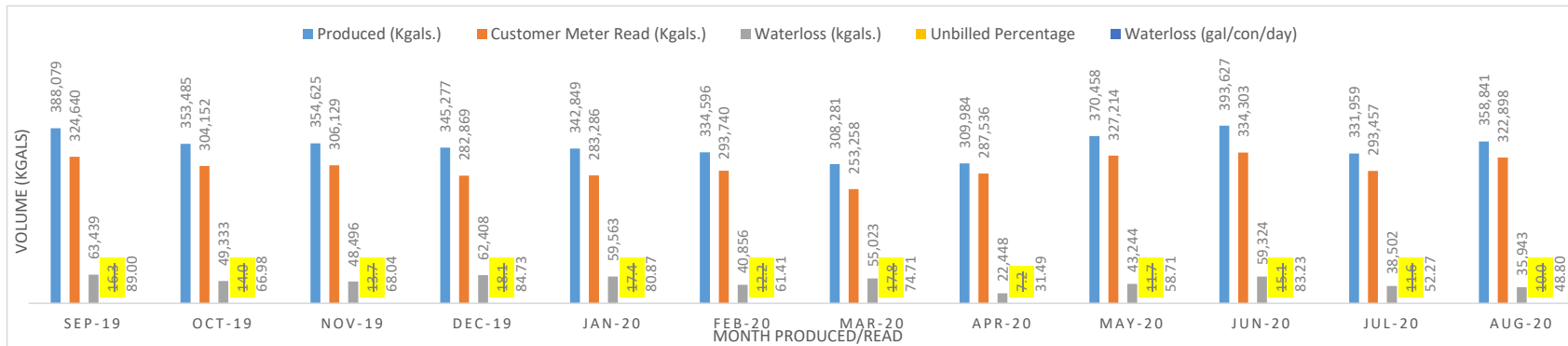

DEPARTMENT OF WATER

County of Kaua'i

"Water has no Substitute – Conserve It!"

MANAGER'S UPDATE

October 22, 2020

Pursuant to Board Policy No. 3

CONTRACTS AWARDED/EXTENSION/AMENDMENTS:

1 FOURTH AMENDMENT TO CONTRACT NO. 639, JOB NO. 17-10, WP2020 #KW-07, REHABILITATE PAUA VALLEY TANK #1, 0.5 MG CONCRETE, KEKAHA WATER SYSTEM, KEKAHA, KAUA'I, HAWAI'I IN THE AMOUNT OF \$212,719.00 AND A CONTRACT TIME EXTENSION OF 150 CALENDAR DAYS

FUNDING:

FROM:			
Account No.	10-00-00-330-000		
Acct Description	Water Utility Fund (unrestricted)	\$	212,719.00
TO:			
Account No.	10-20-00-604-001		
Acct Description	WU/Eng/Admin Capital Outlay – Rehabilitation and Replacement / Capital Purchases		
Funds Available	<i>Verified by WWC, Per Approved Manager's Report No. 21-12</i>		\$ 212,719.00
Contract No.	639		
Vendor	KAI Hawai'i, Inc.		
	Contract Amount	\$	88,844.40
	First Amendment	\$	68,795.00
	Second Amendment	\$	11,636.00
	Third Amendment	\$	4,779.00
	Total Funds Certified To Date	\$	174,054.40
Fourth Amendment:			
	Soil Sampling and Removal Plan, and additional contract time extension	\$	212,719.00
	Total Amendment	\$	212,719.00
		\$	<212,719.00>
	Contract Amount To Date	\$	386,773.40

BACKGROUND:

Contract NTP Date: July 10, 2017
Original Contract End Date: March 16, 2018
First Amendment End Date: May 4, 2019
Second Amendment End Date: November 6, 2019
Third Amendment End Date: TBD
New Contract End Date: 150 additional calendar days, TBD

The DOW started Job No. 17-10, WP2020 Project No. KW-07 Rehabilitate Paua Valley Tank #1, 0.5MG Concrete to address the aging tank located in Kekaha and to perform repairs, including fixing a leak located at the base of the tank. As part of the project, DOW performed hazardous material surveys to ensure proper disposal of any material intended to be removed. Results of the hazardous material survey identified the presence of polychlorinated biphenyls (PCBs) within the interior liner of the tank, which required the shutdown of the tank and the involvement of the Department of Health Hazard Evaluation and Emergency Response Office (HEER) and the Environmental Protection Agency (EPA) to provide direction of proper removal and disposal of the PCBs.

After discussions with HEER and EPA, specifications needed to be provided for proper removal and disposal of the interior liner of the tank. Additionally, the soils in the drainage ditch needed to be tested for the presences of PCBs, as this is where the tank discharges overflow or washout water. This additional scope necessitated the first amendment to the contract.

Testing from the drainage ditch resulted in the presence of PCBs within the soils. Requirements from EPA require that a PCB soil removal plan must be developed and approved by the EPA and HEER for proper mitigation of the soil in the ditch. Therefore, the second contract amendment was necessary to complete the PCB soil removal plan to satisfy requirements from HEER and EPA.

During the initial stages of construction, the Contractor submitted an RFI requesting that the exterior paint be tested for PCB contamination on the basis that two other DOW tanks have recently tested positive for PCBs in the exterior paint. PCB sampling in the exterior paint is not typically required by the Department of Health or EPA, but the DOW voluntarily chose to sample the exterior coatings of the Paanau Tank No. 1 and Kaua'i Inn Tanks as part of Job No. 18-02, the Island-Wide Tank Rehabilitation of Tanks Project. The positive results from those two tanks led the Contractor to request that the Paua Valley Tank project be tested on the basis that they were built during the same timeframe and may have used similar materials.

DOW staff met with EPA Region IX to request a determination as to whether PCB testing of the exterior paint was required. The EPA representative stated that PCB testing is not a standalone requirement; however, it was clarified that based on case law in California, the EPA can now "reasonably require" the DOW to test the exterior paint for PCBs at the Paua Valley tank because two other tanks in the DOW system tested positive. Therefore, the DOW is now proceeding with testing the tank's exterior paint for PCBs. Should the results indicate that PCBs are present, additional mitigation will be needed for the removal and disposal of the paint and the Contractor will submit a change order for the project.

In the third Amendment the scope of the contract with KAI included the removal of "Additional efforts needed to obtain NPDES Individual Permit" for a contract deduction of \$4,781.12 and the addition of "PCB sampling in the exterior paint" with additional funding in the amount of \$4,779.00. The net difference is a deduction of \$2.12 and therefore no additional funds are needed.

In the fourth Amendment the scope of the contract with KAI includes the preparation of a soil testing plan, soil sampling and testing for PCBs. The additional fee of \$212,719.00 includes contingency tasks that are dependent on the outcome of the initial testing and any additional testing required. If PCBs are not

MANAGER'S UPDATE

Re: Manager's Update for September 2020 to October 2020

October 22, 2020

Page 3 of 8

detected in the initial site testing after the outside tank and roofing material are removed, additional testing will not be needed and the fees for the contingency sampling and testing will not be expended. We have reviewed the proposal from KAI Hawai'i, Inc. for additional services for the work and time extension of 150 days and find it acceptable. Reference Manager's Report No. 21-12.

2 SEVENTH AMENDMENT TO CONTRACT. NO. 666, JOB NO. IT-2014, REVIEW AND UPDATE I.T. STRATEGIC PLANNING, IMPLEMENTATION AND SUPPORT IN THE AMOUNT OF \$160,000.00 AND A CONTRACT TIME EXTENSION FOR JANUARY 31, 2021

FUNDING:

FROM:			
Account No.:	10-00-00-330-000		
	Water Utility Fund (unrestricted)	\$	160,000.00
TO:			
Account No.:	10-02-10-540-010		
	WU/IT/Admin/Professional Services		\$ 160,000.00
Funds Available	<i>Verified by WWC, Reference Manager's Report No. 21-07</i>		
Contract No.	666		
Vendor	Brio Consulting, LLC		
	Contract Amount	\$	79,979.00
	Contingency	\$	201.00
	First Amendment	\$	9,820.00
	Second Amendment	\$	70,000.00
	Third Amendment	\$	229,380.00
	Fourth Amendment	\$	79,860.00
	Fifth Amendment	\$	144,000.00
	Sixth Amendment	\$	687,986.00
	Total Funds Certified To Date	\$	1,301,025.00
Seventh Amendment:			
	Contract Time Extension and Additional Funds	\$	160,000.00 \$ <160,000.00>
	Total Amendment	\$	160,000.00
	Contract Amount To Date	\$	1,461,025.00

BACKGROUND:

Contract NTP Date:

September 1, 2018

Original Contract End Date:

December 29, 2018 (Stop Work Orders were issued on this

contract to provide DOW staff to review the Draft I.T. Strategic Plan

First Amendment End Date: July 24, 2019
Second Amendment End Date: November 15, 2019
Third Amendment End Date: January 25, 2020
Fourth Amendment End Date: March 15, 2020
Fifth Amendment End Date: June 30, 2020
Sixth Amendment End Date: December 31, 2020
New Contract End Date: January 31, 2021

The Department of Water (DOW) currently has two (2) vacant positions, Waterworks Information Technology Manager (WITM) and Information Technology Specialist (ITS) III, in its Information Technology (IT) Division. Due to the vacancy created with the loss of the Department's WITM, on October 14, 2019, the DOW executed the Second Amendment to Contract No. 666, Review and Update the Department's Information Technology Strategic Plan and IT Project Implementation and Support with Brio Consulting to incorporate Task 1, Support IT Infrastructure. The contract amendment provided the Department with a mechanism for long term support services during periods when one or both of the remaining I.T. employees are on leave.

The DOW has been actively trying to fill the WITM position. During the course of the WITM position recruitment, the ITS III position became vacant and further elevated the necessity to utilize Brio Consulting's IT support services to keep the Department's critical business systems operating. The need for the consultant IT support services are required until the vacant positions are filled as well as during the transition period of recruitment, to operate and maintain the Department's IT systems.

The Seventh Amendment to Contract No. 666 provides services until January 31, 2021 while the IT positions are vacant and recruitment, interview and hiring action from the Department of Human Resources are being complete. The DOW anticipated that to have the WITM position filled in July, however, the selected candidate declined the Department's offer. Re-recruitment of the WITM position is in process and the process for recruitment of the ITS III will follow. It is anticipated that the WITM position hiring action will be complete by January 31, 2021.

Additional funds are requested to continue Task 1, for IT infrastructure support, of this contract until January 31, 2021 to keep business critical systems of the Department in operation. Reference Manager's Report No. 21-07.

WAIVER, RELEASE & INDEMNITY APPLICATIONS:

None

STAFF REPORTS - FY 20-21:

PERSONNEL MATTERS

October 12, 2020

Administration

1. Manager and Chief Engineer. Position in recruitment.
2. Senior Clerk #2479. Working with DHR on re-description request.

I.T. Division

1. Information Technology Specialist III #2475, #2615. Positions vacant.
2. Waterworks IT Manager #2485. Interviews completed. Working with DHR to hire selectee.

Fiscal Division

- 1. Customer Service Representative I #2305. Working with DHR on recruitment and classification request.

Engineering Division

- 1. Civil Engineer II #2458. Working with DHR on filling vacancy.

Construction Management Division

- 1. Civil Engineer V #2355. Working with DHR on filling vacancy.

Operations Division

- 1. Assistant Water Plant Operator #2312. Pending list of eligibles.
- 2. Construction & Maintenance Worker I #2401. Start date: 10/1/2020.
- 3. Groundskeeper #2601. Completed interviews. Working with DHR on start date.
- 4. Pipefitter #2418. Interviews scheduled for mid-October.
- 5. Pipefitter Helper #2471. Interviews scheduled for late October.
- 6. Plant Electrician #2457. Pending list of eligibles.
- 7. Water Meter Mechanic #2409. Working with DHR on recruitment.
- 8. Water Service Investigator II #2617. Working with DHR on filling position.
- 9. Maintenance Worker I #2611. Pending referred list of eligibles.

Pursuant to Board Policy No. 24

CONVEYANCE OF WATER FACILITIES \$17,550.00

10/15/2020	Carswell/Spalding Partnership, a General Domestic Partnership	3-3-13:025	Lihu'e	\$17,550.00
------------	---	------------	--------	-------------

CUSTOMER CARE AND BILLING (CC&B) SYSTEM UPDATE:

The DOW has been working with Badger Meters and Beacon to get our system ready for the next phase of our transitions to cellular endpoints within our meter system. We will be in the process of updating our meters, to collect data more accurately and more efficiently. We will also be migrating to a new Beacon software.

We will be starting the testing phase on Tuesday 10/13/20. working with our partners, Badger Meter, Beacon and Prithibi consulting. We will be doing this in a test environment in order to get the bugs out and also to train our employee on the changes being made. We anticipate in accomplishing this within the next month to month and a half.

I.T. STRATEGIC PLAN UPDATE:

These updates will be placed in the Quarterly reports per Board action during the July 26, 2019 Regular Board meeting. The current update is in the October 25, 2019 Regular Board meeting.

I.T. INITIATIVES UPDATE:

October 13, 2020

Information Technology continues to work diligently to assist the Department to adapt to the COVID-19 challenges. Support to improve the DOW IT network with upgrades and maintenance of the server system continues. The IT Division continues to be on track to migrate to Microsoft Office 365 in early November 2020.

Candidate interview were held on October 1 & 2, 2020 for the Waterworks Information Technology Manager position. A prospective candidate was selected and the Department has forwarded its recommendations to DHR for review and approval for the position offer.

QUARTERLY UPDATES – 3rd Quarter (July – September 2020)

WATER QUALITY QUARTERLY REPORT:

1. Engineering continues to work with the Lab and contractors to install sample stations in new subdivisions. The new subdivision behind the Po'ipū Shopping Center will also have a sampling station. They will be added to the updated sampling plan required by new Total Coliform Rule. One has been installed in the current Hanamā'ulu project. One more slated for the expansion of the Ulu Ko subdivision. The Lab incorporated the Hanamā'ulu Station into the Routine Sampling Plan in 2020. The Po'ipū Subdivision station is pending. Sampling Points are being looked at to update the site list before end of year when the Compliance Monitoring Data Portal (CMDP) is implemented. Two new sites were added to the RTCR site list. The next sample station may in the new Kulana Subdivision after it is conveyed to DOW.
2. Micro data is being submitted to CMDP website. Hawaii is still in the test environment, however, SDWB is saying we are going real time shortly. Covid19 has slowed thing down.
3. Continued microbiological sampling of sources to see if any will present problems with fecal indicators. This is part of the Triggered Monitoring part of the Ground Water Rule.
4. Phase 2-5 sampling for the 2020-2021 period has begun with System 400 scheduled for 3rd and 4th Quarter 2020.
5. Baseline Chemistry for sources ongoing. pH at Wainiha Well is low. The existing soda ash equipment at Wainiha #2 initially boosted the pH to 7.0. We are monitoring it monthly with the addition of alkalinity testing and it seems to be holding. Testing results are sent to SDWB for their records. SDWB has put the system on an advanced monitoring schedule for Lead and Copper (20 samples 2x/year). This is problematic as it is difficult to get volunteers out there because mostly, it is vacation rentals. However, both rounds were accomplished with results below the Action Level so Sys.415 only has to sample once in 2019 which was completed. Sampling also occurred in July of 2020.
6. Contract for analytical services with Eurofins has been extended to FY 2020-2021. Contract executed. RTM has been submitted for FY2020 budget. RTM was not submitted for 2021 as contact covers 2021 fiscal year.
7. Updated sample site plan and sites on Xcel spreadsheet. Continuing.
8. Lab inspection for microbial analysis certification was completed virtually due to Covid 19. Passed, next inspection will be April, 2022.
9. Microbiological analysis ongoing with no coliform hits.
10. Maintenance and filter replacement completed for RO system. Although we may have to do water suitability testing anyway. Connected autoclave to RO system to use more water. It seems to be working as we are getting conductivity readings below 1.0 uU/cm. Still good.
11. UCMR 4 – Updating SDWARS inventory and scheduling. Sys. 400 AM1, AM2 and AM3 UCMR4 is completed for 2019. Last UCMR4 sampling will be in October at SWTP.
12. PCBs found in Paua Valley tank. Tank has been isolated. Lab is working with SDWB and Engineering to get tank back on line. Ongoing.
 - a. On Kauai entry points to distribution (EPD) are usually after the well head and before the storage tanks. The reason for this is because well water can go into the distribution system before going to a storage tank. This is common to most of DOW sources.
 - b. Therefore, chemical (and to a limited extent, microbiological) samples are taken at the EPDs before going to the storage tanks. DOH does not require sampling from the tanks unless it represents an EPD. There are two tanks that qualify, the Kalaheo Deep Well Tank and the Anahola Tanks.

- c. Because of the recent findings, we are requesting sampling taps on the storage tanks (many do not have them). OPS has installed taps on most of the tanks in question. They have been sampled for PCB.
- 13. sampling and testing with the DOH Lab continues.
- 14. Microbiological QA/QC items for certification completed for 3rd Qtr. 2020.
- 15. Monitoring of chlorides in Sys. 406 ongoing. Waipa Well back in service.
- 16. All Lab personnel are working in Lab. Everyone on 5-8 work schedule.
- 17. Working with Brown and Caldwell on GAC system in Wailua Homesteads. We will be doing the required sampling and paying for the testing.
- 18. Will be looking at the Moalepe Tunnel chlorination project again to revive it.
- 19. The Grove Farm Surface Water Treatment Plant was taken offline for two months while a color issue was being investigated. It is now back on line and the color has cleared.

Pursuant to Board Policy No. 25

COUNTY ATTORNEY QUARTERLY REPORT:

CLAIMS SETTLED: NONE

Claimant(s)	Date of Loss	Filed with Office	Date Closed	Basis of Claim	Claim Amount	Settled Amount	Corrective Action Recommendation
Aiu, Ernest	1/13/2020-7/14/2020	09/25/2020		Partial Reimbursement: Claimant said on Jan. 13, 2020 thru July 14, 2020 the water meter during these period produced erroneous high reading, which resulted in over charges of \$953.86.	\$953.86		Pending review; new claim

DEPARTMENT OF WATER'S CAPITAL IMPROVEMENT PROJECTS REQUESTS FOR STATE AID FOR FY 2020-2021 UPDATE

None

Charter Section 17.04 relating to the minimum requirements for the position of Manager and Chief Engineer of the Department of Water, ballot question

SHALL AN INDIVIDUAL WHO HAS EXTENSIVE WORK AND SUPERVISORY EXPERIENCE IN AN ENGINEERING OR RELATED FIELD ALSO BE QUALIFIED TO SERVE AS MANAGER AND CHIEF ENGINEER OF THE DEPARTMENT OF WATER SUPPLY?

Charter Language: Section 17.04. Staff. The [~~board shall appoint an engineer duly registered under Hawai'i state laws pertaining to registration of engineers~~] manager and chief engineer shall be appointed and may be removed by the board of water. Said person [~~shall be known as the manager and chief engineer and~~] shall be the head of the department. The manager and chief engineer may but is not required to be an engineer duly registered under Hawai'i state laws pertaining to registration of engineers, and shall have had a minimum of five years of training and experience in an engineering related position, at least three years of which shall have been in a responsible administrative capacity. Said person shall have the powers and duties prescribed by the board. (Amended 1980)

*(Language to be deleted is bracketed and stricken through. Language to be added is underlined.)

ADVISOR REPORT TO THE BOARD OF WATER SUPPLY UPDATE

Period ending September 30, 2020

- Handled emails, calls and texts from staff
- Discussions with Chair Akamine and staff on various matters
- Discussions with Construction Division on various projects
- Participated in and/or conducted DH/Leads weekly meeting
- Participated in DOW Board Meeting
- Discussion on Kapa'a Tank (Esaki Easement)
- Discussion on Hanapepe WL RFI Claims

Attachment: BAB Spend down

Mgrrp/Manager's Update (October 22, 2020):mja

2010 Bond Encumbrance and Spend Down Status (Dollars)

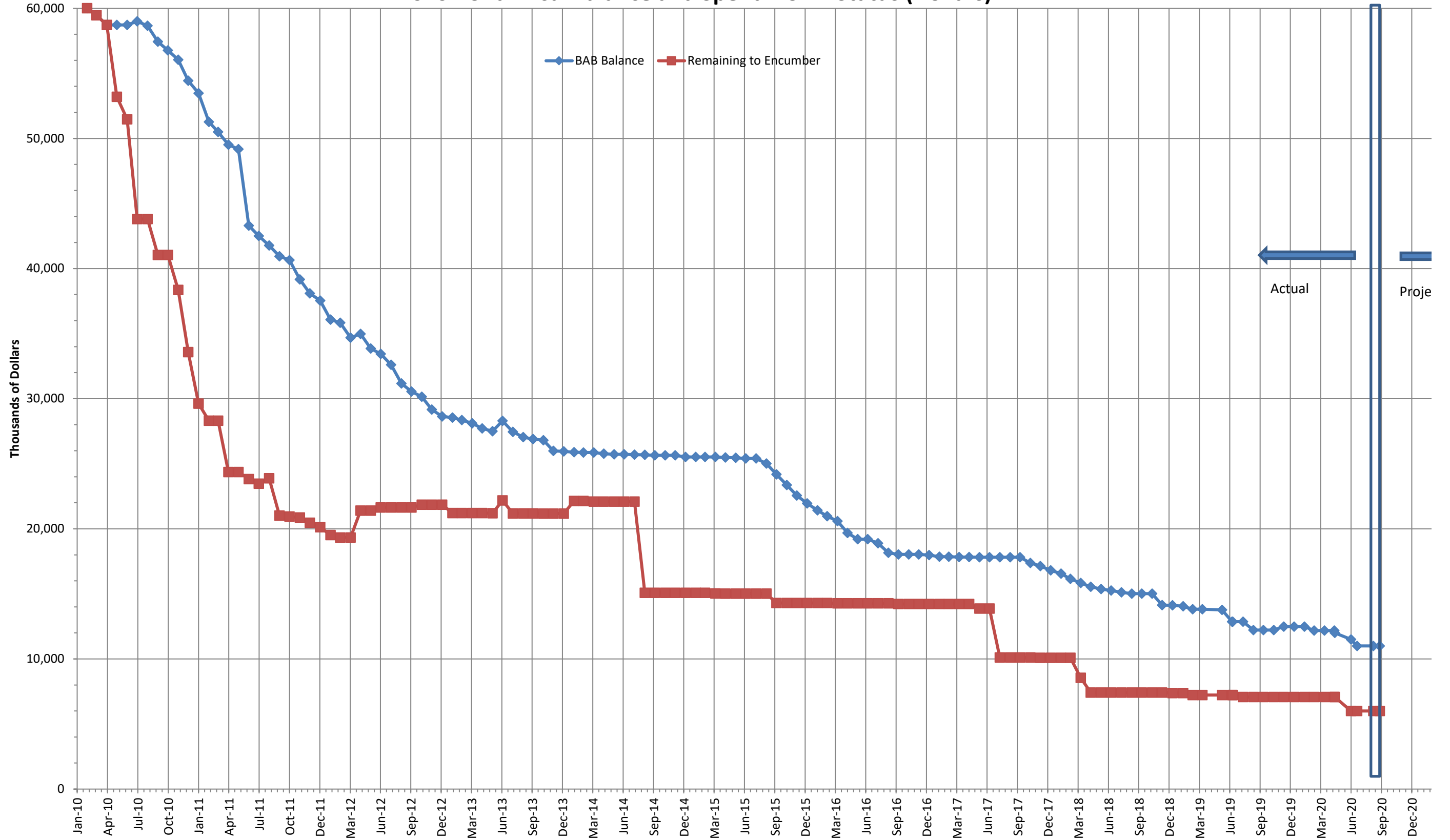

Quarterly Reports

Quarterly Status of **DOW Projects**

Period of July 1, 2020– September 30, 2020

CONSTRUCTION MANAGEMENT DIVISION

Submitted by Dustin Moises, P.E.

Department of Water
October 22, 2020

EXECUTIVE SUMMARY

The significant changes for Water Plan 2020 Projects within the CM Division during this quarter are:

Current WP 2020 CM Design Reviews:

Current WP 2020 Construction:

1. Job No. HE-01– Kaumuali'i Highway 16" Main and Emergency Booster Pump Connection – In construction. Anticipated construction contract completion by end of calendar year.
2. Job No. HE-10 – Hanapepe Road 6" Main Replacement – In construction. Anticipated construction contract completion by end of calendar year.
3. Job No. WK-08, WK-39 – Kapaa Well 4 Drainage line & Kapaa Well 4 Drill & Test– In construction. Working to complete well casing and awaiting drainage system resolution with land owner to complete projects.
4. Job No. PLH-35B – Kapaia Haul Cane Road 18" Transmission Line –Issued extension of stop work order until December 31, 2020 while design team completes UOA and SHPD process.
5. Rehabilitate Paua Valley Tank #1, 0.5MG. – Issued NTP, January 2020. Contractor met requirements for preconstruction meeting which was held on June 2, 2020. However design issues have delayed start of physical construction until those issues are resolved and change order approved if needed. Issued stop work order until October 31, 2020.

Upcoming WP 2020 Construction Projects: CM RFP/IFB Reviews:

1. Kukuiolono 0.2 MG Tank Demolition – Advertised. Bid opening September 10, 2020. Bids under review.
2. Kīlauea Well 1 & 2 Site Improvements – Advertised and received single bid. Bid was found to be nonresponsive. DOW design team revising IFB bid documents based on procurement responses. Awaiting DOW admin to provide revised finalized bid documents for reprocurement for readvertisement.

Private Construction Projects:

1. Certificate of completion – 7 projects.

- **Current WP 2020
Construction Projects**

Construction Projects – Water Plan 2020

WP 2020 NUMBER	JOB NO	PROJECT TITLE	% COMPLETE JUNE 2020	% COMPLETE SEPT 2020	ORIGINAL ESTIMATE TO COMPLETE	CURRENT ESTIMATE TO COMPLETE	CURRENT CONTRACT AMOUNT
HE-01	15-07	Kaunualii Highway 16" Main and Emergency Booster Pump Connection	64 (10)	76 (10)	Q3 2019	Q4 2020 (9 & 11)	\$10,927,028.61
HE-10	15-07	Hanapepe Road 6" Main Replacement					Combined with HE-01
WK-39& WK-08	02-14	Kapaa Well 4 Drainage line & Kapaa Well 4 Drill & Test	85	86	Q3 2019	Q1 2021 (9 & 11)	\$2,382,043.35
KW-07	17-10	Paua Valley Tank Repairs	0	4	Q2 2021	Q4 2021 (12)	\$2,264,750.00
PLH-35B	16-02	Kapaia Haul Cane Road 18" Transmission Line	7	7	Q3 2019	Q4 2021 (8)	\$4,127,545
						TOTAL =	\$19,851,678.44

- (1) Change order issued which extended project schedule.
- (2) Awaiting close out documents
- (3) Awaiting contract dispute resolution
- (4) Awaiting DPW road permit signoff
- (5) Contract closed out
- (6) Liquidated Damages being enforced
- (7) Awaiting Building Permit signoff
- (8) Project issued stop work order and is on hold due to litigation, SHPD, UOA issues
- (9) Redesign required additional time
- (10) Progress made but new change order amounts were substantial and reduced work completed to contract amount ratio.
- (11) Project issued stop work order due to COVID-19
- (12) Project issued stop work order due to redesign needed

Water Plan 2020 Construction Projects

Previous 4 quarters				
QUARTER	OCT - DEC 2019	JAN – MAR 2020	APR-JUN 2020	JUL-SEP 2020
CONSTRUCTION CONTRACTS AWARDED	0	1	0	0
CONSTRUCTION CONTRACTS COMPLETED	2	0	0	0
OPEN CONSTRUCTION CONTRACTS (#)	3	4	4	4
OPEN CONSTRUCTION CONTRACTS (\$)	\$21,703,086.51	\$19,351,435.86	\$19,623,597.86	\$19,851,678.44

- **Upcoming WP 2020
Construction Projects**

Water Plan 2020 CM Design/RFP Review Status

OCTOBER 2019– DECEMBER 2019

WP 2020 No.	PROJECT TITLE	DESIGN STATUS	IFB/RFP STATUS
WKK-15	CONSTRUCT KILAUEA 466 TANK, 1.0 MG	REVIEWED FINAL DESIGN REVIEW SET	AWAITING FINAL SET FOR IFB REVIEW
HW-11	CONSTRUCT 0.2 MG HAENA TANK, 144' SYSTEM	REVIEWED PREFINAL DESIGN SET	WILL REVIEW IFB WITH FINAL DESIGN REVIEW
PLH-01A	GROVE FARM TANKS REPLACEMENT	RECEIVED SIGNED SET	RFP CANCELLED – PROJECT SHELVED MARCH 2017
WK-08	KAPAHI HOMESTEADS 2-0.5 MG STORAGE TANKS	REVIEWED FINAL DESIGN REVIEW SET	REVIEWED FINAL SET. AWAITING BID DOCS
WKK-03	MCC, CHLORINATION FACILITIES FOR KILAUEA WELLS 1 & 2	REVIEWED PREFINAL DESIGN SET	AWAITING DOCS TO REBID
K-01, K-12	KALAHEO CLEARWELL TANK, YAMADA TANK AND PIPELINE (PACKAGES A, B AND C)	REVIEWED FINAL DESIGN SET	AWAITING FINAL SET FOR IFB REVIEW
ANI-01A	ANINI PIPELINE PHASE 2	RECEIVED SIGNED SET	RFP CANCELLED – PROJECT SHELVED APRIL 2017
K-05A	KUKUIOLONO 0.5 MG TANK (886')	REVIEWED PREFINAL DESIGN SET	WILL REVIEW WITH FINAL PLAN REVIEW
	KUKUIOLONO 0.2 MG TANK DEMOLITION	REVIEWED FINAL DESIGN SET	REVIEWING BIDS RECEIVED
	ISLANDWIDE REHAB OF KAUAI INN AND PAANAU TANK 1	REVIEWED PRELIMINARY DESIGN SET	AWAITING IFB SET WITH PREFINAL DESIGN SET
	KUHIO HIGHWAY (HARDY-OXFORD) 16" MAIN REPLACEMENT	REVIEWED PRELIMINARY DESIGN SET	AWAITING IFB SET WITH PREFINAL DESIGN SET

Note: DOW CM Division reviews all WP 2020 or DOW funded plans prior to design completion. Green indicates work during this quarter. **PAGE 96**

Future Water Plan 2020 Construction Projects

FY 19-20						
WP 2020 No.	PROJECT TITLE	STATUS	% EXP	% R&R	ANTICIPATE NTP	EST. COST
	KUKUIOLONO 0.2 MG TANK DEMO	IN DESIGN	0	100	FEBRUARY 2021	\$0.75 M
WKK-03	MCC, CHLORINATION FACILITIES FOR KILAUEA WELLS 1 & 2	IN DESIGN	0	100	MID 2021	\$3.755
K-01, K-12	KALAHEO PACKAGES A, B, C	IN DESIGN	VARIES		JUNE 2021	\$19.0M
WKK-15	KILAUEA 1.0 MG TANK	IN DESIGN	100	0	OCT 2021	\$5M
WK-08	KAPAHI 2-0.5MG TANKS	IN DESIGN	100	0	MAR 2022	\$11.5M
					TOTAL =	\$40.005M

* Optimistic estimate at this time – DOW CM will procure no more than 3-4 projects per year or have more than 4 active projects due to staffing capabilities.

- **Private Construction Projects**

Construction Projects – Private

TMK #	OWNER	DESCRIPTION	STATUS	CERT. OF COMPLETION
3-7-03:012; 3-8-02:012	Grove Farm	Improvements to Existing Hanamaulu & Kapaia Wastewater Pump Station		9/14/2020
	State of Hawaii - DOT - Harbors Division	Installation of Lift Station and Force Main		9/22/2020
5-2-04:099	County of Kauai	Agricultural Water System Crossing at Kilauea Road for Aina Hookupu O Kilauea		9/21/2020
2-6-14:042	Kukuiula Development Company, LLC	Construction Plans for Lopaka Paipa Blvd.		9/21/2020
NONE	Kukuiula Development Company, LLC	Kōloa 69kV Transmission Line Relocation		9/21/2020
2-3-12:003	HoiHui LLC	Construction Plans for Lot 114-A-1 [Kalaheo Hmstd]		9/24/2020
2-8-08:001	Kōloa Village LLC	Construction Plan for Commercial Site		9/24/2020

Construction Projects – Private

TMK #	OWNER	DESCRIPTION	STATUS	CERT. OF COMPLETION
1-6-08:006	Ahe Group/Kaua'i Habitat	Waimea Huakai and Habitat Affordable Housing [S-2019-10]	In Construction	
1-6-08:006	Ahe Group/Kaua'i Habitat	Waimea Huakai Affordable Housing OFFSITE [S-2019-10]	In Construction	
NONE	State DOT	Hanapēpē River Bridge (Federal Highways)- Permanent	Awaiting Precon	
2-1-01:052 (por)	COK - Dept. of Public Works	Mahea Road Sidewalk	Awaiting Closeout Docs	
2-1-01:052 (por)	Kauai Habitat for Humanity	Sidewalk Improvement Plans Eleele Iluna Phase 2 Subdivision Increment 1	Awaiting Closeout Docs	
(4)2-1-003:017; (4)2-3-012:030; (4)2-6-004:057; (4)2-6-004:058	Department of Human Services Hawaii Public Housing Authority State of Hawaii	AMP 38 Infrastructure, Site & Water Improvements, & Installation of 8" RPDA at Hale Hoonanea (HA 1055), Kalaheo Homes (HA 1022), Kawailehua Federal (HA 1086) & Kawailehua State (HA 2204) Eleele, Kalaheo & Koloa Kauai Hawaii [HPHA]	In Construction	
2-3-02:108; 2-3-02:111	Kealakaa Partners LLC	Construction Plans for Makaio Estates & Lalena Gardens		
2-4-01:083	Sharon Gonzalez	Water Meter Plan for Lot 6 Unit A	In Construction	
2-5-01:Por 2	Kauai Bible Church	Kauai Bible Church Highway Access	Awaiting Closeout Docs	
2-6-03:031; 2-6-03:068	Kukuiula Development Company, LLC	Electrial Plans for Kukui'ula Antenna Site	Awaiting Closeout Docs	
2-6-15:014 (por)	Kukuiula Development Company, LLC	S-2016-02 - Kahela Subdivision [Parcel H]	Awaiting Precon	
2-6-19:017; 2-6-19:018; 2-6-19:019; 2-6-19:026; 2-6-19:029; 2-6-19:031	Kukuiula Development Company, LLC	S-2019-09 - Parcel FF	In Construction	

Construction Projects – Private

TMK #	OWNER	DESCRIPTION	STATUS	CERT. OF COMPLETION
2-6-20:022	Kukuiula Development Company, LLC	Kainani Villas-Phase I	Awaiting Closeout Docs	
2-6-21:005	Kukuiula Development Company, LLC	S-2019-13 - Kainani Villas Phase 2	In Construction	
2-8-14:038	Timothy Beckman Trust	S-2019-04 - Water Meter Plan for Lot C	Awaiting Precon	
2-8-16:004	Vistana Sheraton Kauai	Vistana Sheraton Kauai Conversion Site Improvement Plan	Awaiting Closeout Docs	
2-6-22:019 por	Kukuiula Development Company, LLC	S-2019-19 - Kukuiula Parcel G	In Construction	
2-6-22:021 por	Kukuiula Development Company, LLC	S-2020-02 - Kukuiula Parcel E	Awaiting Precon	
2-8-22:033-4	Blake and Kathy Hillis Trust	Proposed Structural Utilities Jacket Crossing Easement W-9	Awaiting Closeout Docs	
NONE	County of Kaua'i	Koae Workforce Housing Development [ELECTRICAL]	Awaiting Closeout Docs	
2-8-06:001	Kōloa Rum Company	Improvements on Maluhia Road	Awaiting Closeout Docs	
2-8-31:184	John H. Murray	Installation of 2nd Single Service Lateral & Backflow Preventor for Lot 184	Awaiting Precon	
NONE	County of Kauai-Department of Public Works	Improvements to Maluhia & Koloa Road	Awaiting Precon	

Construction Projects – Private

TMK #	OWNER	DESCRIPTION	STATUS	CERT. OF COMPLETION
3-3-02:001	Grove Farm	Construction Plans for Sewer Lateral for Lot 1528 (Puhi Road & Kaneka Street Intersection)	Awaiting Closeout Docs	
3-3-11:002; 3-3-11:005; 3-3-18:005	Grove Farm	Construction Plans for 8" Sewer Line	Awaiting Closeout Docs	
3-3-13:017	Extra Space Management	Installation of 6-Inch RPDA for Lot 1105 [Puhi Industrial]	Awaiting Precon	
3-3-13:23	Hawthorne Pacific Corporation	Construction Plans for Hawthorne Pacific Corporation Facility	Awaiting Precon	
3-3-13:025	Carswell/Spalding Partner	2nd Water Service Installation Plan for Lot 1113	PreFinal issued – Awaiting closeout docs before completing	
	State-DOT	Nawiliwili Road Improvements Phase I (Kaumualii HWY to Kanani St.)	Awaiting Closeout Docs	
3-6-17:057	Steve Trinh	Water Service Connection Single Service Lateral for Unit 2	Awaiting Precon	
3-8-05:002 por	COK	Lihue Affordable Housing Homeless Families (LAHFF)	Awaiting Closeout Docs	
3-8-05:028; 3-8-05:029	County of Kauai	Pua Loke Affordable Housing	In Construction	
NONE	COK-DPW	Līhu'e Town core Mobility and Revitalization Project (Kūhi'ō Hwy to Rice St.) [TGR-0700(073)]	Awaiting Closeout Docs	
	County of Kauai	Kamalu Bridge Erosion Protection Repairs	Awaiting Closeout Docs	
	County of Kauai	Kamalu Road Culvert Emergency Repair	Awaiting Closeout	

Construction Projects – Private

TMK #	OWNER	DESCRIPTION	STATUS	CERT. OF COMPLETION
	County of Kaua'i	Puuopae Bridge Replacement	Awaiting Closeout Docs	
4-2-06:	COK-DPW	Opaekaa Bridge Repair/Rehabilitation [Federal Aid Project No. BR-0700(60)]	In Construction	
4-3-02:015; 4-3-02:016; 4-3-02:020	SPD II Makawa Resort Developmet LLC	Water System Improvements @ Coconut Beach Resort	Awaiting Closeout Docs	
4-3-03:004	Troy & Renee Johnston	Water Service Installation Plan for Twin Lakes Condominium Unit 4	Awaiting Precon	
4-3-03:005	AOUA Kulana	Kulana Subdivision OFFSITE Water System & 0.25 MG Tank	In Construction	
4-3-01:001	AOUA Kulana	Kulana Subdivision ONSITE Phase 1	Awaiting other DOW Staff sign off before issuing COC	
4-3-03:005	Steven W. Long & Associates	Relocation of Hauiki Road	In Construction	
4-3-11:001		Kulana Subdivision Roadways & Onsite Water System Phase II	In Construction	
4-5-10:001	Aloiau Inc.	Water Meter Relocation Plan for Dragon Treasures LLC Lot 8	Awaiting Precon	
4-5-12:024	South Pacific Bistro Inc.	1-Inch Water Meter Plan for Lot 1	Awaiting Precon	
4-6-04:	County of Kauai	Kapahi Bridge Replacement	Awaiting Closeout Docs	
4-6-06:093	Anuenue Gardens LLC	Cut & Plug Water Lateral for Lot 5	Awaiting Closeout Docs	

Construction Projects – Private

TMK #	OWNER	DESCRIPTION	STATUS	CERT. OF COMPLETION
4-6-07:010; 4-6-07:040	Hauiki Hui LLC	Construction Plans for Lot 83 - WATERS	In Construction	
NONE	State of Hawaii-Department of Transportation	Kuhio Hwy Short Term Improvements - Kuamoo Rd.- Temporary Kapaa Bypass	In Construction	
5-1-04:007; 5-1-04:008	Jeffrey Lindner	Water Meter and Fire Protection Service Connections for Bertleman's Subdivision	Awaiting Closeout Docs	
5-2-04:009		Kilauea Community Ag Parks Underground Electric & Communication Service	In Construction	
5-2-12:035/915	Charles Somers	Water Service Installation Plan for Lot 8-W-9-A (Parcel 35)	Awaiting Closeout Docs	
NONE	County of Kaua'i	Kahilihoho Road Emergency Repairs	Awaiting Closeout Docs	
(4) 5-1-05:105	Bruce Martin 2007Trust	Water Service Connection Single Service Lateral for Pu'u Pane Subdivision Phase 1 [MARTIN]	Awaiting Closeout Docs	
5-5-05:003	Scott Morison	Water Relocation Plan for Wahi Lani	Awaiting Precon	
5-5-06:016	Hanalei Ozone LLC	WS Installation Plan for Parcel 16	In Construction	
5-5-10:073; 5-5-10:074	Jay & Nicole Welsh	Water Service Installatin Plan for Parcel 73; Lot 28-A	Awaiting Closeout Docs	
5-6-04:023/853	Waipa Foundation Community Cultural Center	Waipa Foundation Community Cultural Center	Awaiting Closeout Docs	
NONE	County of Kaua'i	Weke Road Emergency Repairs	Awaiting Closeout Docs	

Construction Projects – Private

TMK #	OWNER	DESCRIPTION	STATUS	CERT. OF COMPLETION
5-8-08:009	Lon Malapit	Water Meter Plan for Lot 62	Awaiting Precon	
5-8-08:014	Kent & Sharon Lucien	Water Improvement Plan for Lot 55	Awaiting Closeout Docs	
5-9-03:001; 5-9-03:029	Katherine Richardson/Jonathan Wichman	Water Service Installation Plan for Lot 148 and Lot 149	Awaiting other DOW Staff sign off before issuing COC	
NONE	SOH - DOT - Highways	WAIKOKO Temp Line	Awaiting Closeout Docs	
NONE	SOH - DOT - Highways	WAIPA Temp Line	Awaiting Closeout Docs	
NONE	SOH - DOT - Highways	WAIOLI Water Line Brackets	Awaiting Closeout Docs	
NONE	SOH - DOT - Highways	WAIPA Permanent Line	Awaiting Closeout Docs	
NONE	SOH - DOT - Highways	WAIKOKO Permanent Line	Awaiting Closeout Docs	

DOW CM Staffing Update

POSITION #	POSITION TITLE	NAME	STATUS
2470	Chief of Construction Management	Dustin Moises	
2355	Civil Engineer V	Vacant	In Recruitment
2484	Civil Engineer III	Claus Bollman	
2351	Civil Engineer II	Takara Kunioka	
2353	Waterworks Inspector III	Jet Levinthol	
2483	Waterworks Inspector II	Craig Shirai	
2357	Waterworks Inspector I	Weston Moniz	
2604	Engineering Program Assistant	Bekki Malapit	

See As Needed CM Staffing Update for additional staff overseen by chief of CM

As Needed CM Staffing Update

Contract #	Company	Contract Amount	Scope
690	Bowers & Kubota	\$700,000	Anticipate Kīlauea Well 1 & 2 MCC Improvements (1 - Project Engineer) Possibly Kukuīolono Tank
637	RM Towill Inc.	\$1,059,069	Hanapēpē Waterlines (State & County Phases)– Provide 1 Project Engineer & 1 Inspector



Quarterly Status of **DOW Projects**

Period of July 1, 2020 – September 30, 2020

ENGINEERING DIVISION

Department of Water

October 22, 2020

Submitted by Keith Aoki, P.E.

EXECUTIVE SUMMARY

The Engineering Division is currently overseeing **22** ongoing **DOW Design projects**, including several multi-phased projects:

Significant updates for this quarter include:

1. Island-Wide Vulnerability and Resiliency Assessment – Job No 19-01. Milestone progress updates include:
 - Meetings held with consultant to discuss strategy, criticality analysis, and update to the Emergency Response Plan.
2. Department of Water Baseyard Master Plan, Job No. 19-02
 - Final draft being reviewed by the DOW. Building permit for temporary Ops offices submitted to Building for review and approval. (The building permit has been conditionally approved, pending comments from the Fire Department, in October)
3. Rehabilitate Paua Valley Tank No. 1, 0.5MG – Job No. 17-10, WP2020 Project No. KW-07:
 - Work on addressing revised scope of work and hazardous material mitigation. Additional funds will be needed. (MR for additional funds placed on agenda for October 22, 2020 Board meeting)
4. Kīlauea Wells No. 1 & 2 MCC, Chlorination – Job No. 16-04, WP2020 Project No. WKK-03
 - Support CM division with responses to pre-bid questions and bid analysis. Working of revising bid documents for re-solicitation.
5. Kapaia Cane Haul Road 18” WL, Job No. 16-02, WP2020 Project No. PLH-35b
 - Grant of Easement completed with land owners. SHPD comments to draft AIS received and are being addressed. Working with State to complete Use and Occupancy Agreements (UOA’s) that the State requires.
6. Hanapēpē-‘Ele‘ele Connecting Pipeline, Job No. 15-07, WP2020 Project Nos. HE-10 & HE-1:
 - Continued support of DOW CM Division for construction matters, including assisting the CM Division with addressing contractor delay claims. RFI history from PM Web and email information was provided to the DOW CM, along with pointing out requirements in the construction contract documents overseen by the CM. It is hoped that this information will help DOW CM to reduce or eliminate the amount of justified delay claim days preliminarily determined by the CM’s analysis.
7. Kukuiolono Tank Demolition:
 - Construction bids under review by DOW. Pending outcome of review.

EXECUTIVE SUMMARY (cont'd)

The Engineering Division is currently overseeing **22** ongoing **DOW Design projects**, including several multi-phased projects:

(Continued) Significant updates for this quarter include:

8. Kalāheo Water System Improvements, Package A – 0.5 MG Yamada Tank, Package B – 0.1 MG Clearwell Tank, Package C Water Main Improvements, Job No. 09-01, WP2020 Project Nos. K-01, K-12
 - Re-certification of plans and re-approval of permits need to be done prior to and within 1 year of start of construction. Coordinating with DOW CM for when construction is planned to be procured to gauge when to start process to re-certify the plans and re-approve the permits.
9. U.H. Experimental Station 0.25 MG Tank – Job No. 12-02, WP2020 Project No. WK-23
 - Continue work to address questions from U.H. regarding proposed water tank site location.
10. Kūhiō Highway Hardy-Oxford 16" WL Replacement – Job No. 18-03, WP2020 Project No. PLH-27
 - 60% plans and specifications being reviewed by the DOW.
11. Hā'ena 0.2 MG Tank – Job No. 15-08, WP2020 Project No. HW-11
 - Final plans in review with DOW.
12. Kīlauea 1.0 MG Tank – Job No. 02-06, WP2020 Project No. WKK-15
 - Continue review process of draft Memorandum of Understanding from Ian Jung for proposed Easement Modification on behalf of Oliver and Constanze Niedermaier (Achberg LLC). Current MOU draft with Achberg for review.
13. Kīlauea Well No. 3 – Job No. 17-11, WP2020 Project WKK-02
 - Draft Right of Entry (ROE) from the land owner received and is being reviewed by DOW.
14. Island-Wide Rehabilitation of Storage Tanks – Job No. 18-02
 - 60% plans and specifications, under review.
15. As-Needed Engineering Services for Indefinite Quantity and Indefinite Delivery
 - Contract executed 7/7/20.
16. Wailua Granular Activated Carbon Evaluation (procurement support)
 - Negotiations and scope completed. Contract in process of being finalized and executed.

EXECUTIVE SUMMARY

Upcoming design projects:

- 1) WK-39, Develop Kapaa Well No. 4 Well Site (pending successful completion of Drill and Test Kapaa Well No. 4 project)
- 2) Manoa Stream WL Repairs

Projects with design estimated to be completed within the next three to six months :

- Job No. 09-01, WP2020 Project Nos. K-01, K-12 Kalāheo Water System Improvements, Package A – 0.5 MG Yamada Tank, Package B – 0.1 MG Clearwell Tank, Package C Water Main Improvements – re-certification of approved plans, permit renewals, and DWSRF loan application requirements.
- Job No. 19-02 Department of Water Baseyard Master Plan
- Job No. 11-03 Land Acquisition, Waimea, (depending on State BLNR review)
- Job No. 02-06 Kīlauea 1.0 MG Storage Tank, WP2020 No. WK-15
- Job No. 15-8, Construct Hā'ena 0.2 MG tank

PRIVATE PROJECTS:

- **27** private project reviews (new and existing) were completed by Engineering during this quarter, including 9 new projects which were submitted for Engineering review during this quarter.
- Waiahi SWTP Improvements – Continuing to review invoices submitted by Waiahi Water Co. per request from Board approved at Feb. 28, 2020 meeting for approved funding of \$2.82M per the Water Treatment and Delivery Agreement.



Design Projects

WEST SIDE DESIGN PROJECTS

Kekaha, Waimea, Hanapēpē, 'Ele'Ele

WP 2020 NUMBER	PROJECT TITLE	% COMPLETE JUN 2020	% COMPLETE SEPT 2020	EST. DESIGN COMPLETE	BUDGET COST (DESIGN)	FRC GENERATING PROJECT?	STATUS
	Island Wide Rehab of Storage Tanks	40%	40%	Q1 2021	\$458,594	No	In design, pursuing ROE's for soil testing/plan. Soil testing added scope..
	Island Wide Vulnerability and Resiliency	30%	60%	Q4 2020	\$629,686	No	In design
KW-28	Amfac Shaft Renovation, Phase 3	0%	0%	-	-	Yes	No change - project on hold indefinitely.
HE-1 & HE-10	Reorganize Water System- Hanapēpē-'Ele'ele Connecting Pipeline	100%	100%	Completed	\$499,972	Yes	In construction Re-design of bridge approved
KW-07	Rehabilitate Paua Valley Tank #1, 0.5 MG Concrete	100%	100%	Completed	\$162,420	No	Addressing design for unexpected field conditions.

SOUTH SIDE DESIGN PROJECTS

Kālaheo, Lawai, Po'ipu, Kōloa

WP 2020 NUMBER	PROJECT TITLE	% COMPLETE JUN 2020	% COMPLETE SEPT 2020	EST. DESIGN COMPLETE	BUDGET COST (DESIGN)	FRC GENERATING PROJECT?	STATUS
K-01	Kālaheo 1111' & 1222' Water System Improvements: Package A (Yamada Tank) Package B (Clearwell Tank) Package C (Water Main) Package D (Yamada Well)	95%	98%	Packages A, B, and C completed. Package D completion TBD	\$1.2 million	Yes	Environmental work to meet SRF requirements completed. Re-certification of plans and re-approval of building permits needed. <u>Package D</u> : - Design to commence after Package A construction is complete.
K-05A	Kukuiolono (Kālaheo) 0.5 MG Tank, 886'	95%	95%	TBD	\$250,253	Yes	DOW working on land exchange. Tank demo project went out to bid.

SOUTH SIDE DESIGN PROJECTS

Kālaheo, Lawai, Po‘ipu, Kōloa

WP 2020 NUMBER	PROJECT TITLE	% COMPLETE JUN 2020	% COMPLETE SEPT 2020	EST. DESIGN COMPLETE	BUDGET COST (DESIGN)	FRC GENERATING PROJECT?	STATUS
KP-09	Kōloa Wells “16A” & “16B”, MCC Improvements, Site and Building Improvements, MCC Chlorination Facilities	100%	100%	Completed	\$300,000	No	Consultant working on drainage overflow discovered after construction.

EAST SIDE DESIGN PROJECTS

Lihu'e-Puhi, Wailua-Kapa'a, Anahola

WP 2020 NUMBER	PROJECT TITLE	% COMPLETE JUN 2020	% COMPLETE SEPT 2020	EST. DESIGN COMPLETE	BUDGET COST (DESIGN)	FRC GENERATING PROJECT?	STATUS
PLH-37	Deepen Puhi Well No. 2	PH 1 is 100%	PH 1 is 100%	-	\$ 67,900	No	No change - Phase II Proposal Pending
PLH-27	Kūhi'ō Hwy (Hardy-Oxford) 16" Main Replacement	50%	50%	Q4 2020	\$270,608	No	60% design in review
N/A	DOW Baseyard Master Plan	95%	95%	Q4 2020	\$301,983	No	Final draft of master plan submitted for review.
(DOW Job No. 18-09)	Makaleha Tunnel Water Line Repair (Rain18 project)	20%	20%	TBD	\$335,820	No	Design on hold pending clarification from FEMA. Will need a new ROE for construction

EAST SIDE DESIGN PROJECTS

Lihu'e-Puhi, Wailua-Kapa'a, Anahola

WP 2020 NUMBER	PROJECT TITLE	% COMPLETE JUN 2020	% COMPLETE SEPT 2020	EST. DESIGN COMPLETE	BUDGET COST (DESIGN)	FRC GENERATING PROJECT?	STATUS
WK-8	Construct Drainage Improvements (Package A) and Kapa'a Homestead 325' Tanks, 1.0MG - Two 0.5 MG Tanks (Package B)	Package B 92% Package A 100%	Package B 92% Package A 100%	Package B Q1 2020 Package A completed	\$989,788	Yes	Resolution for drainage pending
WK-23	Wailua Homesteads 0.25 MG Tank site - U.H. Experimental Station Phase 1	35%	35%	TBD (2021)	\$50,000	Yes	DOW working on land rights
WK-39	Kapa'a Homesteads Well #4 drill and test	100%	100%	Design is complete	\$ 352,000	Yes	In construction with the drainage Package A Drainage Improvements - Kapa'a Homesteads 325' Tanks. Drainage needs to be resolved prior to pump test.

NORTH SHORE DESIGN PROJECTS

Moloa'a, Kilauea, 'Anini, Hanalei, Ha'ena

WP 2020 NUMBER	PROJECT TITLE	% COMPLETE JUN 2020	% COMPLETE SEPT 2020	EST. DESIGN COMPLETE	BUDGET COST (DESIGN)	FRC GENERATING PROJECT?	STATUS
MO-03	Land and Well Acquisition, Moloa'a and Waimea	100% (Moloa'a) Waimea - 90% Complete TBD	100% (Moloa'a) Waimea - 90% Complete TBD	Moloaa complete Waimea TBD – Dependent on State BLNR	\$161,278	No	Moloa'a portion of contract complete. Waimea land acquisition ongoing. State is requiring DOW to resolve mapping discrepancy with DOT for Waimea tank and well site. Pending DOT research and response.
M-02	Construct Moloa'a 0.10 MG Tank	25%	25%	TBD	\$ 119,207	Yes	No change Contract amendment needed. DOW reevaluating project and priority.
WKK-15	Kilauea 1.0 MG Tank	95%	95%	Q4 2020	\$367,884	Yes	final plans submitted to DOW for review
WKK-2	Drill and Develop New Kilauea Well No. 3	15%	15%	TBD	\$370,000	Yes	Design cannot proceed until land rights for the well are obtained. Draft ROE received by DOW. Under review.
	Mānoa Stream Water Line Repair	0%	0%	TBD	\$250,000	No	Negotiating with selected consultant

NORTH SHORE DESIGN PROJECTS

Moloa'a, Kilauea, 'Anini, Hanalei, Ha'ena

WP 2020 NUMBER	PROJECT TITLE	% COMPLETE JUN 2020	% COMPLETE SEPT 2020	EST. DESIGN COMPLETE	BUDGET COST (DESIGN)	FRC GENERATING PROJECT?	STATUS
WKK-03 & WKK-21	MCC, Chlorination Facilities – Kilauea Wells No. 1 & 2 & Replace Kilauea Well #2	100%	100%	Completed	\$349,168	No	Design being revised for construction re-solicitaion.

NORTH SHORE DESIGN PROJECTS

Moloa'a, Kīlauea, 'Anini, Hanalei, Ha'ena

WP 2020 NUMBER	PROJECT TITLE	% COMPLETE JUN 2020	% COMPLETE SEPT 2020	EST. DESIGN COMPLETE	BUDGET COST (DESIGN)	FRC GENERATING PROJECT?	STATUS
HW-11	Construct 0.2 MG Storage Tank Project, 144', Ha'ena	90%	90%	Q4 2020	\$412,401	Yes	Conservation District Use Permit approved by BLNR and Board of Water.
HW-12	Drill and Test Wainiha Well #4	75% (Re-design)	75% (Re-design)	TBD	\$133,740	Yes	Alternate well site agreed upon. Contract amendment needed. Proposal from consultant to be submitted to DOW.
N/A	Rain18 Repair Mānoa Stream Water Line	0%	0%	TBD	TBD	No	Negotiating with selected consultant for design.

Private Projects of Note

Area	DEVELOPMENT OR DEVELOPER	PLAN REVIEW STATUS (as of 9/30/2020)
Hanapepe	COK – Hanapēpē Stadium Complex Improvements	DOW awaiting resubmittal
Lawai	DOT – Kaumualii Hwy Improvements (Lauoho-Kuli)	DOW awaiting resubmittal
Lawai	Kōloa Road 8" Pipeline Replacement, Ph I	approved
Koloa	COK Safe Routes to School	approved
Koloa	Waihohonu CPR (Z-III-2015-2) - Recertification	DOW awaiting resubmittal
Koloa	Kōloa Makai 3" Water Meter	approved
Koloa	Kōloa Community Sewer Main	In review
Koloa	Kukui'ula Kōloa Estates PRV	DOW awaiting resubmittal
Poipu	Kukui'ula parcel CC West Ph 2	DOW awaiting resubmittal
Līhu'e	Waiola Subdivision Ph I	approved
Līhu'e	Waiola Subdivision Ph II (S-2009-14)	DOW awaiting resubmittal
Līhu'e	Waiola Subdivision Ph III (S-2009-15)	DOW awaiting resubmittal
Lihue	Wilcox Emergency Generator Project RPDA	approved
Lihue	Ahukini Makai Subdivision-onsite (S-2005-41)	DOW requested mylars to sign- pending submittal
Lihue	Ahukini Makai Subdivision-offsite (S-2005-41)	DOW awaiting resubmittal

Private Projects of Note

Area	DEVELOPMENT OR DEVELOPER	PLAN REVIEW STATUS (as of 6/30/2020)
Līhu'e	COK Puhi Road Rehabilitation, Phase II	DOW awaiting resubmittal
Lihue	COK King Kaumuali'i Safe Routes to School	approved
Lihue	Ahukini Makai Subdivision (S-2005-41)	DOW awaiting resubmittal
Lihue	Niumalu Paradise Condominium	In review
Anahola	KIUC Anahola Service Center (Main extension)	approved
Kapa'a	COK-Kawaihau, Hauaala, Mailihuna, Complete Streets	approved
Kapa'a	DOT-Mailihuna Road Water Main Extension	In review
Kapa'a	COK-Impr. To Collector Roads: Olohena, Kukui, Ulu	DOW awaiting resubmittal
Kilauea	Kilauea Ag Park Electric Crossing	approved

Personnel Status

Civil Engineer VI	Keith Aoki
Civil Engineer V	Bryan Wienand
Civil Engineer V	Vacant
Civil Engineer V	Vacant
Civil Engineer II	Vacant

QUARTERLY UPDATE

Period of July 01, 2020 to September 30, 2020

WATER RESOURCES AND PLANNING DIVISION

Submitted by: Edward Doi, P.E.

DEPARTMENT OF WATER

October 22, 2020

Executive Summary

The significant changes for this quarter are:

- Represent the Department and participate with neighbor island Managers for statewide water utility coordination and reporting. Recent topics include sharing of information and processes regarding the evolving COVID-19 situation and coordination with DOH for their contingency planning.
- WRP division staff Michael Hinazumi continues to volunteer and in the interim oversee the Information Technology Division.
- The Division prepared proposed rule amendments to address the FRC impact fee to size limited dwellings, Guest Houses containing kitchens and Affordable Rental Units (ARUs). The Board held a virtual environment public hearing and with no opposition, the rule amendment was adopted and became effective, June 15, 2020.
- The Division continues to work with Manager to address requests for FRC exemptions for customers affected by the “Grace Period” rule.
- The Division continues to assist other Divisions with the overall review of DOW water infrastructure needs and island wide project prioritization.
- The Division continued to assist other Divisions regarding the Water Audit (CWRM)

Water Restriction Policy

Water System / System	Sub-	Restrictions (5/8-inch water meter or number units per lot)	Inadequate Facilities	Comments
Upper Lawai		2	Storage	Administration Approved
Poipu		300	Storage	Board Approved (50% of new tank allowed for new development; 50% to make up storage deficit)
Wailua Homesteads		5	Storage	Administration Approved
Upper Wailua Homesteads		2	Storage	Administration Approved
Kapaa Homesteads		5	Source	Board Approved
Moloa'a		0	Source and Storage	Water Purchase Agreement
Kilauea-Kalihiwai		5	Source and Storage	Administration Approved
Aliomanu – Kukuna Road		0	Transmission	Administration Approved
Anini		1	Source and Storage	Water Purchase Agreement
Upper Wainiha Valley		1	Storage	Administration Approved
Wainiha – Haena		3	Storage	Administration Approved

Completed Tasks

	July – September 2020
Subdivision Applications; Zoning / Land Use / Variance Permits; Zoning Amendments; ADU/ARU Clearance Applications	18
Water Service Requests	50
Building Permit Applications	516
Backflow Inspection Program – No. of Tested Devices	1642

Personnel Status

Chief of Water Resources and Planning	Edward Doi
Civil Engineer VI	Michael Hinazumi
Civil Engineer III	Regina Flores
Civil Engineer II	Vacant
Civil Engineer I	Vacant
Engineering Drafting Technician IV	Vacant
Engineering Support Technician IV	Vacant



INFORMATION TECHNOLOGY DIVISION QUARTERLY UPDATE

July 1, 2020 – September 30, 2020

Update provided by: Michael Hinazumi

October 22, 2020

COVID-19 TELEWORK RESPONSE

- 39 DOW employees authorized to telework
 - Purchased 25 laptops
 - Repurposed 14 laptops
 - Purchased VPN licenses allowing laptops to be connected to the DOW network

- Researching network updates

IT STRATEGIES



TECHNOLOGY



BUSINESS PROCESS
IMPROVEMENTS

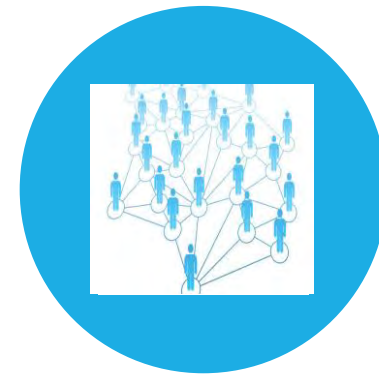

ORGANIZATION

TECHNOLOGY

- Upgrade M-PET with a GIS-based Work Management System
 - Implementation completed
- Upgrade SCADA and Replace Servers
 - Implementation completed
- Upgrade Firewall System
 - Implementation completed
- Core IT Infrastructure Upgrades
 - O365 Cloud Migration mid Q2 Kickoff
- Upgrade Financial Information System
 - Dynamics 365 Cloud Migration, beginning Q3 Kickoff
- Develop GIS Technologies and Processes
 - On hold until I.T. Manager is hired

BUSINESS PROCESS IMPROVEMENTS

- CC&B Process Evaluation
 - Mid Q2 Kickoff
- Improve Use of SharePoint
 - PR/Admin portals were created
 - O365 Cloud Migration, mid Q2 Kickoff

ORGANIZATION

Position Title	Personnel
Waterworks Information Technology Manager	Vacant – Active Recruitment
Information Technology Specialist III	Vacant
Information Technology Specialist III	Vacant
Computer System Support Technician I	Darrell Acob

DEPARTMENT OF WATER

County of Kaua'i

"Water has no Substitute – Conserve It!"

MANAGER'S REPORT No. 21-12

RECEIVED FOR THE RECORD

October 22, 2020

Re: Discussion and Possible Action on the Fourth Amendment to Contract No. 639 Job No. 17-10, WP2020 Project No. KW-07 Rehabilitate Paua Valley Tank #1, 0.5MG Concrete, with KAI Hawaii Inc. for a time extension of 150 days and for additional design funding in the amount of \$212,719.00

RECOMMENDATION:

It is recommended that the Board approve a second amendment to Contract No. 639 with KAI Hawaii Inc. for the subject project for a time extension of 150 days and additional design funding in the amount of \$212,719.00.

FUNDING:

Account No.	10-20-00-604-000			
Acct Description	WU/Eng/AdminCapitalOutlay-Rehabilitation and Replacement			
Funds Available	Water Utility Fund -Unrestricted			\$ Fiscal to provide
Contract No.	639			
Vendor	KAI Hawaii, Inc.			
	Contract Amount	\$	93,625.52	
	Amendment 1 Additional Amount	\$	68,795.00	
	Amendment 2 Additional Amount	\$	11,636.00	
	Amendment 3 Amount (Credit)	\$	-2.12	
	Total Funds Certified To Date	\$	174,054.40	
Amendment:				
	Additional Funds Requested for Amendment 4:	\$	212,719.00	
	Proposed New Contract Amount	\$	386,773.40	
	Fund Balance			\$ Fiscal to provide

BACKGROUND:

Contract NTP Date: July 10, 2017
 Original Contract End Date: March 16, 2018
 New Contract End Date: Estimate March 21, 2021

The DOW started Job No. 17-10, WP2020 Project No. KW-07 Rehabilitate Paua Valley Tank #1, 0.5MG Concrete to address the aging tank located in Kekaha and to perform repairs,

including fixing a leak located at the base of the tank. As part of the project, DOW performed hazardous material surveys to ensure proper disposal of any material intended to be removed. The presence of polychlorinated biphenyls (PCBs) within the interior of the tank was not expected, based on DOW prior tests for PCBs of the tank water. However, results of the hazardous material survey identified the presence of polychlorinated biphenyls (PCBs) within the interior liner of the tank (testing for PCBs on exterior of tank was not required), which required the shutdown of the tank and the involvement of the Department of Health (DOH) Hazard Evaluation and Emergency Response Office (HEER) and the Environmental Protection Agency (EPA) to provide direction of proper removal and disposal of the PCBs. Design mitigation of PCBs if detected was not included in the scope of work.

First Amendment (executed May 15, 2018)

After discussions with HEER and EPA, specifications needed to be provided for proper removal and disposal of the interior liner of the tank. Additionally, the soils in the drainage ditch needed to be tested for the presences of PCBs, as this is where the tank discharges overflow or washout water.

Second Amendment (executed September 11, 2019):

Testing from the drainage ditch resulted in the presence of PCBs within the soils. Requirements from EPA require that a PCB soil removal plan must be developed and approved by the EPA and HEER for proper mitigation of the soil in the ditch. Therefore, the second contract amendment was necessary to complete the PCB soil removal plan to satisfy requirements from HEER and EPA. EPA clarified that construction of the tank rehabilitation was not dependent on the soil removal plan and mitigation of the soil in the ditch and could proceed independently from the soil mitigation of the ditch. The DOW decided to proceed with the construction of the tank rehabilitation.

Third Amendment (executed June 8, 2020):

During the initial stages of construction, the Construction Contractor submitted an RFI requesting that the exterior paint be tested for PCB contamination on the basis that two other DOW tanks have recently tested positive for PCBs in the exterior paint. PCB sampling in the exterior paint is not typically required by the Department of Health or EPA, but the DOW voluntarily chose to sample the exterior coatings of the Pa'anau Tank No. 1 and Kaua'i Inn Tanks as part of Job No. 18-02, the Island-Wide Tank Rehabilitation of Tanks Project. The positive results from those two tanks led the Construction Contractor to request that the Paua Valley Tank project be tested on the basis that they were built during the same timeframe and may have used similar materials.

DOW staff met with EPA Region IX to request a determination as to whether PCB testing of the exterior paint was required. The EPA representative stated that PCB testing is not a standalone requirement; however, it was clarified by EPA that based on case law in California, the EPA can now "reasonably require" the DOW to test the exterior paint for PCBs at the Paua Valley tank because two other tanks in the DOW system tested positive. Therefore, the DOW proceeded with testing the tank's exterior paint for PCBs. Should the results indicate that PCBs are present, additional mitigation will be needed for the removal and disposal of the paint and the Construction Contractor will submit a change order for the project.

Fourth Amendment (proposed):

The PCB sampling results for the exterior paint and roof coating on the Paua Valley Tank (Reservoir No. 1) were positive for PCB. As a result of this, EPA is requiring testing of the soil

and asphalt paving surrounding the reservoir. Additional environmental and engineering work are required to comply with EPA and DOH requirements. Depending on the test results further testing and mitigation may be required. We have reviewed the proposal from KAI Hawaii, Inc. for additional services required and find it acceptable.

The EPA is requiring that PCB testing of the asphalt and soil around the tank be done after the construction of the exterior tank work is completed. The DOW is considering an option for the DOW to voluntarily complete non-required testing of the first layer of asphalt and soil prior to the start of the construction work on the exterior of the tank to establish a baseline of PCB detected concentrations, if any. If pre-construction testing is done, the testing after the construction of the exterior work on the tank will still be required by EPA. The proposed Fourth Amendment will allow the testing of the first layer of asphalt and soil to be done prior to construction of the exterior of the tank if the DOW chooses to do so. If the DOW decides to complete the pre-construction testing, it will require an additional contract amendment and Board approval of additional funds (estimated at \$80,000) to be approved at a future Board meeting to complete the post construction (exterior work) testing that is required by the EPA.

At this time the DOW has not made a determination if the non-required testing prior to the start of construction of the exterior of the tank should be done or not. The DOW staff will provide a recommendation to the Manager for consideration upon completion of the analysis.

Summary of Design:

- **July 10, 2017** - Original contract NTP – Consultant completed hazardous material testing required in the contract scope of work. Consultant test results report in December 2017 included detection of PCBs in the interior lining of the tank. DOW did not expect this. (note: testing of the tank exterior for PCBs was not required by DOH or EPA at that time and not included in the design scope of work)
- **May 15, 2018** – 1st Amendment to contract executed. Amendment is to address EPA requirement for DOW to mitigate/dispose of interior tank lining and to test soil in drainage ditch (off-site from tank site) for PCBs.
- **September 11, 2019** – 2nd Amendment to contract executed. Amendment is to address PCBs being detected in the soil samples from the drainage ditch and subsequent EPA and DOH HEER requirements to address the PCB detected in the ditch soil. EPA clarified that construction of the Paua Tank can proceed, as it is not contingent on the mitigation of the PCB detected in the drainage ditch soil. DOW decided to proceed with construction and a construction contract was executed.
- **June 8, 2020** – 3rd Amendment to contract executed. Amendment is to address Construction Contractor's request to test exterior of tank for PCBs and subsequent EPA determination that the testing of the tank exterior needed to be done. This Amendment is for the consultant to complete the additional testing required by EPA.
- **October 22, 2020** – Proposed 4th Amendment to contract. Amendment is to address PCBs being detected in the exterior paint and roofing material of the tank and subsequent EPA requirement to test the asphalt paving and soil surrounding the tank for PCBs.

OPTIONS:

Option 1: Approve \$212,719.00 in additional funds for the subject contract.

Pro: This will allow DOW to adhere to requirements from HEER and EPA to develop an approved plan and test for PCB contaminated asphalt/soils around the Paua Valley 0.5 MG tank.

Con: Additional funds will be expended.

Option 2: Do not approve \$212,719.00 in additional funds for the subject contract.

Pro: Additional funds will not be expended.

Con: The DOW will not be able to adhere to the requirements from HEER and EPA to develop an approved plan and test for PCB contaminated asphalt/soils around the tank site. The project cannot be completed.

KA/ein

Mgrpp/October 2020/21-12/Discussion and Possible Action on the Fourth Amendment to Contract No. 639 Job No. 17-10, WP2020 Project No. KW-07 Rehabilitate Paua Valley Tank #1, 0.5MG Concrete, with KAI Hawaii Inc. for a time extension of 150 days and for additional design funding in the amount of \$212,719.00 (10-22-20):ein